



Warsaw

# USER MANUAL

issue 1WGFxW1

# WG /Fx

STANDALONE GAS DETECTOR  
OF STANDARD DESIGN,  
WITH REPLACEABLE SENSOR  
models: **WG-nn.Fx**, **WG-nE.Fx**,  
**WG-nKL.Fx**, **WG-nR.Fx**

series [ W1 ]

BEFORE installation, read the entire USER MANUAL.  
Proceed with the installation only after fully understanding  
the contents of this Manual.



-to ensure safety during the installation and operation  
of the detector, it is mandatory to observe the  
recommendations and warnings in this User Manual  
marked with this symbol.

Keep this manual available for reference by the user  
of the gas detection system.



	Page
<b>1.</b> Intended use	<b>2</b>
Functional features/block diagram/description	<b>3</b>
WG/Fx series with a semiconductor sensor	<b>5</b>
WG/Fx series with an electrochemical sensor	<b>6</b>
WG/Fx series with a catalytic sensor	<b>8</b>
WG/Fx series with an IR optical sensor	<b>9</b>
<b>2.</b> Technical parameters	<b>10</b>
<b>3.</b> Optical and acoustic signalling	<b>11</b>
<b>3.A</b> Output functions	<b>12</b>
<b>4.</b> Installation conditions	<b>13</b>
<b>5.</b> Detector installation	<b>14</b>
<b>5.5</b> Test procedure	<b>17</b>
<b>6.</b> Maintenance / operation	<b>18</b>
<b>6.2</b> Sensor replacement	<b>20</b>
<b>7.</b> Warranty conditions	<b>22</b>

Meaning of the graphical symbols located on the device:

	WARNING! If this symbol appears, read the safety instructions in the user manual to understand the nature of the potential hazards and the necessary steps to avoid them.
	INFORMATION! If this symbol appears, consult the device's user manual to ensure correct installation and safe use.
	The device is designed to be powered by direct current (DC).
IP44	Ingress protection rating of the device enclosure according to PN-EN 60529
	Under the Waste Electrical and Electronic Equipment Act of 11 September 2015, the used module must not be disposed of with general household waste. It must be taken to a designated waste collection point. Proper disposal prevents waste from negatively impacting human health and the environment.

PRODUCER: **GAZEX**  
**gazex** Baletowa 16, PL 02-867 Warsaw, POLAND  
 Tel: +48 22 644 2511 gazex@gazex.pl  
 www.gazex.com

©gazex '2026. All rights reserved. The gazex logo, the name gazex, dex, ASBIG, and Active Gas Installation Safety System are registered trademarks of the GAZEX company

**With Us, You Work and Live SAFER !!!** ©gazex

## GLOSSARY OF ABBREVIATIONS USED IN THIS MANUAL:

- WG/Fx** – standalone gas detector with a semiconductor, electrochemical, catalytic, or infrared optical sensor; (hereinafter referred to as "WG")
- gas detector** – a device that converts a varying concentration of gas, mist, or vapour of a specific substance into an electrical signal;
- gas sensor** – an electronic component sensitive to changes in the concentration of gas in the air;
- MS** – sensor module = a printed circuit board containing a gas sensor, a connection socket, and a microprocessor, often fitted with a filling insert; a replaceable part of the detector;
- calibration gas** – the type of gas or vapour of a substance in the presence of which alarm thresholds are configured (usually the target medium the detector is designed to detect);
- A1** - detector alarm state = signifies that the concentration of the calibration gas around the detector has exceeded the value of the first (lowest) alarm threshold, subject to specific time constraints (e.g. the average value over the last 15 minutes) or the concentration value of the first alarm threshold;
- A2** - detector alarm state = signifies that the concentration of the calibration gas around the detector has exceeded the values of both the first and second (higher) alarm thresholds, subject to specific time constraints (e.g. the average value over the last 15 minutes) or the concentration value of the second alarm threshold;
- A3** - detector alarm state = signifies that the concentration of the calibration gas around the detector has exceeded the value of the third (highest) alarm threshold, or the concentration value of the third alarm threshold;
- definitions of A1/A2/A3 values:  
(**s15**) = average value over the last 15 minutes,  
(**p2**) = momentary exceedance of the concentration value;
- "window"** detector – a detector with a sensor module where at least one alarm threshold is set for a decrease in concentration, and the remaining ones for an increase (most commonly applies to oxygen detectors);
- calibration** – testing the response of the detector or sensor module to the calibration gas and adjusting the alarm levels so they correspond to the predetermined values of A1, A2, A3;
- abbreviated calibration certificate [SSW]** – a document confirming the correct response of the detector (A1, A2, A3 states) to the medium specified in the document, at specified concentrations, under specific conditions;
- TWA** – Time Weighted Average for harmful substances in the working environment (in accordance with the Regulation of the Polish Minister of Family, Labour and Social Policy of 12 June 2018, Journal of Laws 2018, item 1286, as amended); 8-hour time-weighted average concentration value;
- LEL** – Lower Explosive Limit of a given flammable substance – the highest volumetric concentration of a mixture of a flammable gas or vapour with air, below which an explosion of this mixture cannot occur (values for individual substances are adopted according to PN-EN ISO/IEC 80079-20-1);
- ppm** - parts per million by volume; **v/v** – volume/volume ratio;
- cable** vs electrical **wire** – a connecting cable is a bundle of several insulated single-core wires (with solid or stranded copper conductors) enclosed in a common insulating sheath;
- <t1/t2** – time limit for the occurrence of a given factor, described as "periodic" or "momentary" – meaning for a duration not exceeding  $t_1$  within a time period not shorter than  $t_2$ .

### 1. INTENDED USE

**WG/Fx** standalone detectors are designed to detect the presence of dangerous concentrations of explosive or toxic gases, vapours of flammable liquids, or oxygen in the air within enclosed industrial spaces. They feature a replaceable sensor module with three alarm thresholds (set during production).

WG/Fx detectors are of standard design and must not be used in zones classified as hazardous areas prone to gas, vapour, or dust explosions.

They have a splash-proof gas sensor cover (applicable only in the recommended mounting position) and can be used outdoors (provided a sun canopy is used).

WG/Fx detectors are available:

with an intelligent semiconductor sensor module – **WG-nn.Fx** models,

with an intelligent electrochemical sensor module – **WG-nE.Fx** models,

with an intelligent catalytic sensor module – **WG-nKL.Fx** models,

with an intelligent infrared (optical IR) sensor module – **WG-nR.Fx** models,

where "**n**" represents the digits forming the code of the sensor module (calibration gas).

Sensor modules for the above detector models are interchangeable (different modules can be used with the same WG/Fx enclosure). However, the installation conditions specific to individual media must be taken into account.

## FUNCTIONAL FEATURES

- REPLACEABLE, intelligent gas sensor: semiconductor – WG-*nn*.Fx models, electrochemical – WG-*nE*.Fx models, catalytic – WG-*nKL*.Fx models, infrared optical – WG-*nR*.Fx models (*where "n" represents the digits forming the calibration gas code*);
- single-unit design – sensor, control circuit, low-volume sounder, LED indicator light, relay outputs, 12V alarm outputs, and power supply, all housed in one enclosure;
- standard 230V AC mains supply; a 24VDC powered WG/Fx-A version is also available (e.g. WG-*nn*.Fx/A);
- **3 alarm** thresholds set during production;
- built-in event history (*analysis available from the manufacturer*), indication of the recommended calibration interval expiry; built-in power-on self-test procedure;
- external testing capability (without unscrewing the detector cover);
- thermal compensation circuit (*allows operation in variable ambient conditions*);
- easy gas permeation through the sensor cover = relatively fast detector response time;
- built-in optical signalling (multi-coloured LED indicator);
- 3 isolated NO relay outputs (including OUT3, configurable as NO or NC; functioning as a FAULT output, an output assigned to the A3 threshold, or a secondary set of contacts for A2 – selectable via a function switch);
- functionality of relay outputs:
  - if the detector has all alarms set in one direction (for excess or deficiency), the alarm state of a higher level also activates lower-level outputs,
  - if the detector has alarms set in different directions (for excess and deficiency – window control, e.g. an oxygen detector), each alarm state triggers only its specifically assigned output;
- removable terminals accommodating solid and stranded wires (without the need for crimping ferrules);
- built-in acoustic sounder (*activated in A1 or A2 state, or disabled – selectable via a function switch*);
- 12V/100mA alarm output for connecting an external beacon/sounder (e.g. SL-32);
- IP44 splash-proof gas sensor cover (in the recommended mounting position);
- optional mechanical guard made of AR-1d profiled tubes (for installation in areas prone to mechanical damage, e.g. warehouses, wholesale depots, car parks);
- WG/Fx sensor modules (round, like those for DG/F and DG/M) are interchangeable (*different modules can be used with the same WG/Fx enclosure*) – however, installation conditions for specific media must be observed!

## BLOCK DIAGRAM OF A SYSTEM WITH WG/Fx

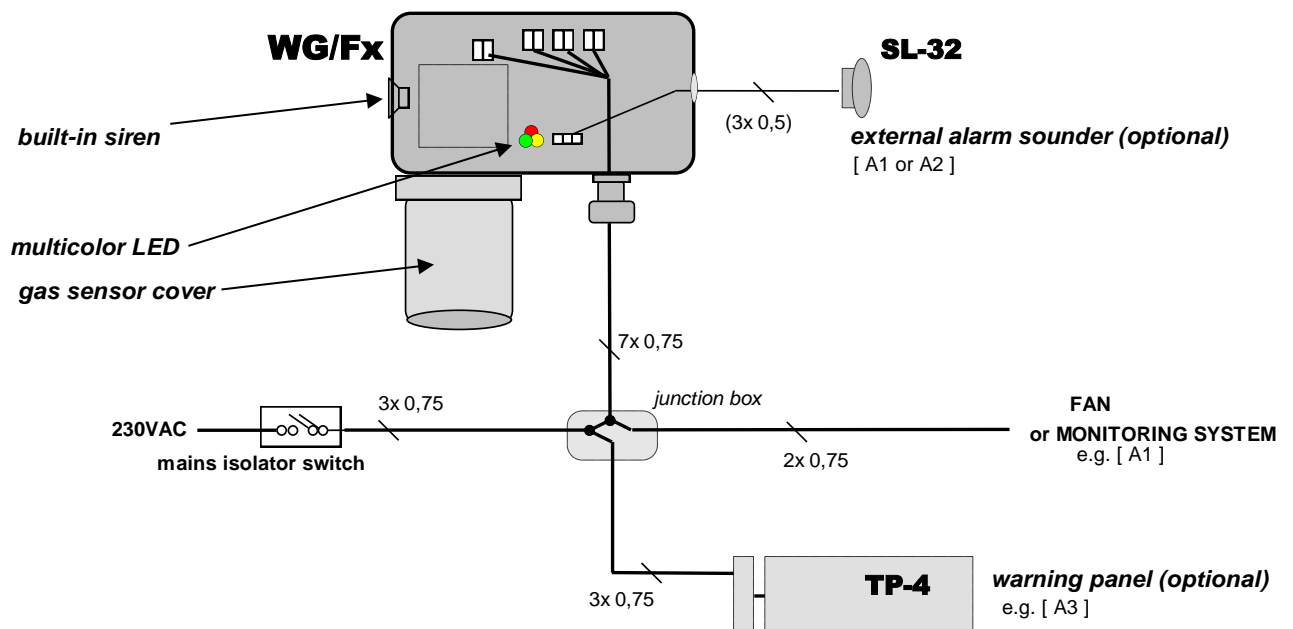

**NOTE:** When selecting all connecting cables and wires, consider the requirements regarding the appropriate reaction to fire classification of the cable, in accordance with Regulation (EU) No 305/2011 of the European Parliament and of the Council of 9 March 2011 (CPR), depending on the installation location within the building structure. Detailed regulations on this matter can be found in the relevant legal acts.



# WG-nn.Fx SERIES

WG/Fx detectors with a replaceable, intelligent semiconductor sensor include the following models:

**TABLE 1.WGFx.nn**

SYMBOL		Concentration RANGE							PERIOD of calibration		Expected lifespan in clean air approx. [years]
		MODEL	sensor module, designation: MS-...	gas / medium	concentration range + selectivity	min. A1 value (recommended)*	max. A2 value (recommended)	permissible momentarily (<1min / 30min)	Standard calibration *** A1/A2/A3	unit	
1	3	4	5	6	7	8	8A	9	10	11**	12
<b>WG-12.Fx</b>	12/N	methane	W	10	40	100	10/30/(40) (p2)	%LEL	36	12	10
<b>WG-14.Fx</b>	14/N	methane (selective)	W	10	40	100	10/30/(40) (p2)	%LEL	36	12	10
<b>WG-15.Fx</b>	15/N	propane-butane	W	10	40	100	10/30/(40) (p2)	%LEL	36	12	10
<b>WG-22.Fx</b>	22/NL2	carbon monoxide	N + SL	20	300	1000	20/100/(200) (s15)	ppm	36	12	10
<b>WG-31.Fx</b>	31/N	organic compounds	W	10	40	50	20/40/(50) (p2)	%LEL	<b>12</b>	12	10
<b>WG-41.Fx</b>	41/N	ammonia	W	300	5000	10000	500/1500/(2000) (p2)	ppm	<b>12</b>	12	10
<b>WG-61.Fx</b>	61/N	Freons****	W	500	3000	10000	1000/2000/(2500) (p2)	ppm	<b>12</b>	12	10
<b>WG-71.Fx</b>	71/N	hydrogen, acetylene	W	10	40	100	10/30/(40) (p2) H2	%LEL	<b>12</b>	12	10
<b>WG-73.Fx</b>	73/N	hydrogen (selective)	W	10	40	100	10/30/(40) (p2)	%LEL	36	12	10

*Custom models with parameters tailored to specific applications are marked in red italics.*

\* parameters may depend on the selection of a sensor for a specific application; the A1 value must not be less than 20% of the A2 value;

\*\* - calibration is also recommended prior to any critical measurement/event significant to the User;

\*\*\* - A1/A2/A3 value: (s15) = average value over the last 15 minutes; (p2) = momentary value of alarm concentrations; the (A3) value in brackets indicates an approximated, estimated threshold;

\*\*\*\* - standard calibration applies to the R410A or R32 refrigerant.

ABBREVIATIONS: SL – enhanced selectivity; N – concentrations considered low in metrological practice;

W – concentrations considered high in metrological practice;

v/v – volume/volume ratio; ppm – parts per million by volume;

LEL - Lower Explosive Limit of a given flammable substance – the highest volumetric concentration of a flammable gas or vapour mixture with air, below which an explosion of this mixture cannot occur (*values for individual substances are adopted according to PN-EN 60079-20-1:2010*).



**NOTE:** detecting media in other ranges or detecting different media is possible = bespoke execution, requiring consultation with GAZEX; in special cases, detector parameters can be tailored to a specific application =

**ANALYSIS OF THE DEVICE'S OPERATING CONDITIONS IS REQUIRED.**

### WARNING - IMPORTANT:

- The sensor used in the detector is resistant to **momentary** increases in the concentration of gases or vapours of substances listed in Table 1.WGFx.nn, column 7. However, prolonged operation of the detector (regardless of its type) in gas concentrations exceeding the value given in col. 7 is **STRICTLY PROHIBITED** for all media listed in the table! This may cause a permanent shift in the detector's measurement parameters or total failure of the gas sensor.
- Prolonged operation of the detector in a concentration range exceeding approx. 3-5% LEL for explosive gases, or above the A1 threshold for a detector calibrated for toxic gas, is **NOT** recommended, as this may result in the aforementioned effect.
- The use of gases with uncontrolled concentrations for functional testing of the detector is **PROHIBITED!**

# WG-nE.Fx SERIES

WG/Fx detectors with a replaceable, intelligent electrochemical sensor include the following models:

**TABLE 1.WGFx.nE**

SYMBOL		Concentration RANGE							PERIOD of calibration		Expected lifespan in clean air approx. [years]
MODEL	module sensor MS...	gas	selectivity	threshold A1 min	threshold A2 max	permissible momentarily (<1 min / 8h)	standard calibration* A1/A2/A3	unit	recommended max.	optimal [months]	
1	3	4	5	6	7	8	8A	9	10	11**	12***
<b>WG-2E.Fx</b>	2E/N	carbon monoxide	SLK	20	500	1500	20/100/200	ppm(N)	12	6	2
<b>WG-4E.Fx</b>	4E/N	ammonia (high concentrations)	SLK	300	1000	2000	500/800/800 (p2)	ppm	6	3	2
<b>WG-4E1.Fx</b>	4E/N1	ammonia (cold stores)	SLK	5	100	200	20/40/60	ppm(N)	6	3	2
<b>WG-4E2.Fx</b>	4E/N2	ammonia (wastewater treatment plants)	SLK	5	100	200	20/40/60	ppm(N)	6	3	2
<b>WG-5E.Fx</b>	5E/N	hydrogen sulphide	SLK	5	100	500	5/10/20	ppm(N)	6	3	2
<b>WG-7E.Fx</b>	7E/N	hydrogen	SLK	500	2000	10000	500/800/2000 (p2)	ppm	6	3	2
<b>WG-9E5.Fx</b>	9E5/N****	oxygen	SLK	2	25	30	19/18/17 (p2)	% v/v	48	48	5
<b>WG-0E.SO2.Fx</b>	SO2/N#	sulphur dioxide	SLK	1	20	150	0.5/1/5	ppm(N)	6	3	2
<b>WG-0E.NO2.Fx</b>	NO2/N#	nitrogen dioxide	SLK	1	30	150	1/3/5	ppm(N)	6	3	2
<b>WG-0E.CL2.Fx</b>	CL2/N#	chlorine	SLK	1	10	50	1/3/5 (p2)	ppm	6	3	2
<b>WG-0E.ETO.Fx</b>	ETO/N#	ethylene oxide	SLK	2	20	100	2/5/10 (p2); s	ppm	6	3	2
<b>WG-0E.HCL.Fx</b>	HCL/N#	hydrogen chloride	SLK	3	30	50	3.4/6.8/10; s	ppm(N)	6	3	2
<b>WG-0E.CLO2.Fx</b>	CLO2/N#	chlorine dioxide	SLK	0.1	1	3	0.1/0.3/0.5; s	ppm(N)	6	3	2
<b>WG-0E.O3.Fx</b>	O3/N#	ozone	SLK	0.2	1	-	0.2/0.3/0.5	ppm	6	3	2

Custom models with parameters tailored to specific applications are marked in **red italics** (sensors can be selected to measure gas concentrations in other ranges or for gases other than those specified above).

SLK (col. 5) - selectivity according to Table 1.2.WGFx.nE;

# - sensor module in an enclosure with reduced water splash resistance (IP33);

s – cross-calibration (using a gas different from the target detection gas, resulting in an increased measurement error);

ppm(N) – denotes calculated thresholds: A1= TWA, A2= STEL (calculated in accordance with the Regulation of the Polish Minister of Family, Labour and Social Policy of 12 June 2018, Journal of Laws 2018, item 1286, as amended), A3 = momentary value;

\* - calibration of A1/A2 thresholds to momentary concentration values is possible – marked as (p2) = bespoke detector, custom-made to order;

\*\* - calibration is also recommended prior to any critical measurement/event significant to the User;

\*\*\* - exceeding the concentrations in col. 8 or the recommended operating temperatures shortens the sensor's life and may necessitate re-calibration;

\*\*\*\* - the parameter stabilisation period after power-up or a momentary power loss is approx. 3 minutes; artificially high oxygen concentration readings may occur for up to approx. 10 minutes (depending on the duration of the power failure) → the detector is designed for continuous operation; emergency backup power for the system with WG-9E5.Fx is recommended!



NOTE:

WG-nE.Fx detectors achieve metrological readiness approx. 5 minutes after power-up.

Exceptions: WG-9E5.Fx as per footnote \*\*\*\*, WG-0E.ETO.Fx requires approx. 24h – these times may depend on the duration of the power failure (emergency backup for the detection system is recommended).

**NOTE: In special cases, the detector (sensor) parameters can be tailored to a specific application = ANALYSIS OF THE DEVICE'S OPERATING CONDITIONS IS REQUIRED.**

**TABLE 1.2.WGFx.nE Cross-sensitivity** – selectivity of selected electrochemical sensors, response to test gas in [ppm]

MS-nE/N (measuring range) concentration:	Test gas - CO 300 ppm	H <sub>2</sub> S 15 ppm	H <sub>2</sub> 1000 ppm	SO <sub>2</sub> 5 ppm	NO 30 ppm	NO <sub>2</sub> 5 ppm	Cl <sub>2</sub> 1 ppm	CO <sub>2</sub> 5000 ppm	ethanol C <sub>2</sub> H <sub>5</sub> OH 200 ppm	NH <sub>3</sub> or other	other
<b>MS-2E/N</b> readings (range 1000 ppm CO)	300	0	<400	0	< 3	0	0	0	0	0	
<b>MS-4E/N</b> readings (range 1000 ppm NH <sub>3</sub> )	0	0	0	- 2	0	0		0	0	(500 ppm): 500	
<b>MS-4E/N1</b> readings (range 100 ppm NH <sub>3</sub> , cold stores from -40°C)	0	-2.3÷0	0	- 1.5	0	-0.4÷0		0	0	(100 ppm): 100	
<b>MS-4E/N2</b> readings (100 ppm NH <sub>3</sub> , wastewater treatment plants)	0	1.5	0	0	0	0		0	0	(100 ppm): 100	C <sub>n</sub> H <sub>m</sub> : 0
<b>MS-5E/N</b> readings (range 100 ppm H <sub>2</sub> S)	< 2	15	< 3	0.5	0.3	- 1		0	< 0.4	0	
<b>MS-7E/N</b> readings (range 10 ppm H <sub>2</sub> )	< 180	~ 0	1000	0		-20	0	0	~	0	CH <sub>4</sub> (1%v/v) 0
<b>MS-9E5/N</b> readings (range 25% v/v oxygen)											OXYG EN (20.9% ): 20.9%
<b>MS-0E.../N</b> readings (range ...)	<b>see the APPENDIX to the DG... detector user manual concerning the cross-sensitivity of sensor modules featuring an electrochemical sensor - TABLE MS-(P)nE...</b>										

Custom models with parameters tailored to specific applications are marked in **red italics**.

Dedicated detection gases are marked with a **green background**.

Agents with a particularly significant impact on the sensor are marked with a **yellow background**.

Re. Table 1.2.WGFx.nE: The influence of other gases is possible, but the degree of their impact is not specified by the sensor manufacturer. The degree of impact of the aforementioned gases may differ for concentrations other than those specified in the header. Blank boxes indicate a lack of sensor manufacturer data (*this should be treated as a possible, albeit unspecified, impact*).

The data for Tables 1.1.WGFx.nE and 1.2.WGFx.nE have been sourced from electrochemical sensor manufacturer materials (updated 11/2023). GAZEX bears no responsibility for the reliability of the aforementioned data.



**NOTE: When selecting a detector for a Customer's specific application, GAZEX may utilise sensors with parameters **different from those specified above**.**

# WG-nKL.Fx MODEL SERIES

The WG-nKL.Fx detector series with an intelligent catalytic sensor includes the following models:

**TABLE 1.WGFx.nKL**

SYMBOL		Concentration RANGE							PERIOD of calibration		
model	sensor module MS-...	gas / medium	concentration range + selectivity	min. A1 value (recommended)	max. A2 value (recommended)	permissible momentarily (<10s/30min)	Standard calibration *** A1/A2/A3	unit	recommended max. [months]	optimal [months]	lifespan* in clean air approx. [years]
1	3	4	5	6	7	8	8A	9	10	11**	12
<b>WG-1KL.Fx</b>	1KL/N	flammable gases (simple hydrocarbons)	W	10	50	110	10/30/50 (p2)	%LEL	12****	6	5
<b>WG-1KL4.Fx</b>	1KL4/N	methane ( <i>selective</i> )	W+SL	10	50	110	10/30/50 (p2)	%LEL	12****	6	5
<b>WG-1KL5.Fx</b>	1K5L/N	propane-butane	W	10	50	110	10/30/50 (p2)	%LEL	12****	6	5
<b>WG-7KL3.Fx</b>	7KL3/N	hydrogen ( <i>selective</i> )	W+SL	10	50	110	10/30/50 (p2)	%LEL	12****	6	5

Abbreviations: W - concentrations considered high in metrological practice;  
 SL - enhanced selectivity (*including low sensitivity to propane, heavier hydrocarbons, and alcohols*).  
 \* - the lifespan of the sensor in WG-1KL.Fx and WG-1KL5.Fx is highly dependent on the presence of silicones, sulphur compounds, and other compounds capable of reacting with the catalyst on the sensor's active surface;  
 \*\* - calibration is also recommended prior to any critical measurement/event significant to the User;  
 \*\*\* - A1/A2/A3 values: (p2) = momentary concentration value;  
 \*\*\*\* - provided functional checks are carried out using a test gas at least every 3 months; otherwise, the recommended calibration interval is 6 months.



**NOTE: detecting media in other ranges or detecting different media is possible = bespoke execution, requiring consultation with GAZEX; in special cases, detector parameters can be tailored to a specific application = ANALYSIS OF THE DEVICE'S OPERATING CONDITIONS IS REQUIRED.**

**WARNING - IMPORTANT:**



- The catalytic sensors used in the detector are not selective within the listed range of explosive (calibration) gases – they may react to flammable gases and vapours as detailed in Table 1.2.nKL below. They may also react to other flammable substances.
- The sensor used in the detector is resistant to **momentary** increases in the concentration of gases or vapours of substances listed in Table 1.WGFx.nKL, column 7. Operating the detector in gas concentrations exceeding those given in col. 8 may cause incorrect detector operation (loss of alarm signals despite the presence of an explosive substance) or a permanent shift in measurement parameters.
- The use of gases with uncontrolled concentrations for functional testing of the detector is **PROHIBITED!**

**TABLE 1.2.nKL** Theoretical relative sensitivity of catalytic sensors relative to methane = 1

Medium	Sensitivity factor	Medium	Sensitivity factor	Medium	Sensitivity factor
methane	<b>1.00</b>	n-octane	0.32	ethylene	0.63
ethane	0.68	methanol	0.78	hydrogen sulphide	0.46
propane	0.51	ethanol	0.63	carbon monoxide	0.79
n-butane	0.52	isopropanol	0.44	ethylene oxide	0.49
isobutane	0.45	benzene	0.45	hydrogen	0.81
n-pentane	0.51	toluene	0.42	acetylene	0.63
hexane	0.40	o-xylene	0.38		
heptane	0.42	acetone	0.60		

The data for Table 1.2.nKL have been sourced from the catalytic sensor manufacturer's materials; GAZEX bears no responsibility for the reliability of the aforementioned data. The aforementioned factors should be treated as approximate; they may differ from actual values for a given sensor unit and may shift during operation.

# WG-nR.Fx SERIES

WG/Fx detectors with a replaceable, intelligent optical (Infrared) sensor include the following models:

**TABLE 1.WGFx.nR**

SYMBOL		Concentration RANGE							PERIOD of calibration		Lifespan in clean air approx. [years]
		gas	selectivity	min. A1 value (recommended)**	max. A2 value (recommended)	permissible momentarily (<1min/30min)	Standard calibration* A1/A2/A3	unit	recommended max. [months]	optimal [months]	
1	3	4	5	6	7	8	8A	9	10	11**	12
<b>WG-1R2.Fx</b>	1R2/N	methane	SL	10	40	++	10/30/50 (p2) methane	%LEL	36	12	>5
<b>WG-1R5.Fx</b>	1R5/N	propane, butane	SL	10	40	++	10/30/50 (p2) propane	%LEL	36	12	>5
<b>WG-3R.Fx</b>	3R/N	petroleum-derived compounds	SL	10	40	++	20/40/50 (p2)	%LEL	<b>12</b>	12	>5
<i><b>WG-6R7.Fx</b></i>	6R7/N	Freons		500	1500	++	500/1500/2000	ppm	36	12	>5
<i><b>WG-6R7.Fx -SF6</b></i>	6R7/N -SF6	SF <sub>6</sub>		500	1500	++	500/1500/2000	ppm	36	12	>5
<b>WG-3R.Fx</b>	8R/N	carbon monoxide (CO <sub>2</sub> )		0.1	5***	100	0.5/1.5/2	% v/v	36	12	>5
<b>WG-8R8.Fx</b>	8R8/N	CO <sub>2</sub> (0+45°C)		0.1	2***	100	0.5/1.5/2	% v/v	36	12	15

Custom models with parameters tailored to specific applications are marked in *red italics*.

\*- A1/A2/A3 values: (p2) = momentary concentration value, other calibrations possible = custom version;

\*\* - calibration is also recommended before any major, user-critical measurement/event;

\*\*\* - parameters (measuring range) may depend on the selection of a sensor for a specific application;

ABBREVIATIONS: SL – selectivity according to Figure 1.2.nR; ++ - no restrictions; LEL - as below Table 1.WGFx.nn

*Detecting other media or in other ranges is possible = bespoke execution, requiring consultation with GAZEX; in special cases, detector parameters can be tailored to a specific application = **ANALYSIS OF THE DEVICE'S OPERATING CONDITIONS IS REQUIRED.***



**FIGURE 1.2.nR** Approximate response of the Infrared sensor to selected hydrocarbons (relative to CH<sub>4</sub>)

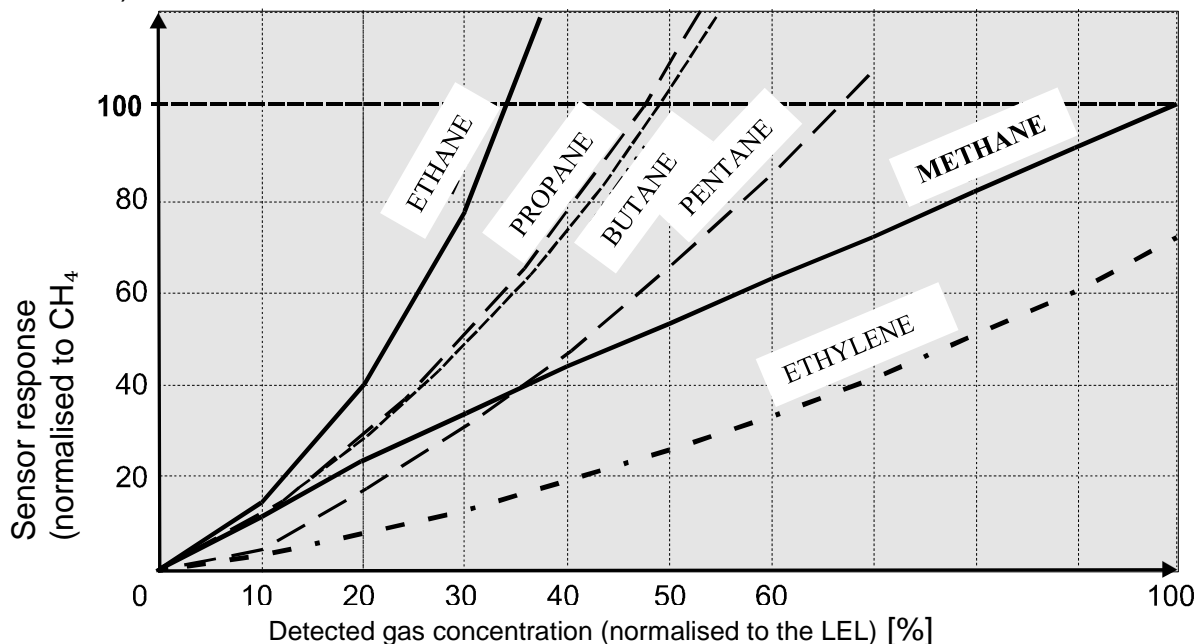

The influence of other gases is possible, but the degree of their impact is not specified by the sensor manufacturer. The data for Figure 1.2.nR have been sourced from the sensor manufacturer's materials (updated 07/2015). According to these data, the sensor used in WG-8R...Fx models is selective (no cross-sensitive gases are listed). *GAZEX bears no responsibility for the reliability of the aforementioned data.*























# TECHNICAL PARAMETERS

**TABLE 2.1.WGFx** Parameters common to all models





Power supply voltage	230V AC ( $\pm 10\%$ ), 50 Hz; in the WG/Fx-A version: 24V DC ( $15 \div 30$ V)
Power/current consumption	< 4W; WG/Fx-A version: < 0.15A @24V
Gas sensor	semiconductor, electrochemical, catalytic, or infrared optical, REPLACEABLE via a sensor module (intelligent, featuring time-weighted average calculation and a built-in event history); interchangeable modules; NOTE: supports only sensor modules with yellow numerical EAN labels
Operating temperature	for WG- <i>nn</i> .Fx: recommended from -10°C to +40°C; permissible ( <i>with increased measurement error</i> ) -20°C to +45°C; permissible periodically (1h/12h) -20°C to +50°C; for WG- <i>nE</i> .Fx (exceptions below): recommended from -20°C to +40°C; permissible periodically (1h/12h) from -25°C to +50°C; exceptions: for WG-9E5.Fx: recommended from -40°C to +50°C; for WG-4E1.Fx: recommended from -40°C to +40°C; for WG-4E.Fx: recommended from -30°C to +50°C; for WG- <i>nKL</i> .Fx: recommended -30°C to +45°C; permissible periodically (1h/12h) from -40°C to +50°C; for WG- <i>nR</i> .Fx: recommended -30°C to +45°C; permissible periodically (1h/12h) from -30°C to +50°C - however, WG-6R7.Fx: recommended -20°C to +45°C; permissible periodically (1h/12h) from -25°C to +50°C; for WG-8R8.Fx: recommended from 0°C to +45°C
Detected gases	as per the sensor module specification; response time: 15 to 300 s (model dependent)
Alarm thresholds	A1, A2, A3 - as per column 8A of Tables 1.WGFx... or upon request; calibrated at the manufacturing stage; relative error of threshold settings under calibration conditions, i.e.: 20(-2/+5)°C, 65( $\pm 10$ )% RH, atm. pressure 1013( $\pm 30$ )hPa, >72h of uninterrupted power supply: $\leq \pm 20\%$ , >25% for cross-calibration – denoted by an 's' in col. 8A in TABLE 1.WGFx. <i>nE</i> ;± long-term stability: for WG- <i>nn</i> .Fx 20%/year but 30%/3 years ( <i>potential tendency for sensitivity increase</i> );±± for WG- <i>nE</i> .Fx no worse than -3%/month ( <i>tendency for sensitivity decrease</i> )
Alarm signal outputs	normally open (NO) contacts; rating: max 2 A ( <i>resistive load or motors</i> ) or max 0.6 A ( <i>fluorescent lamps</i> ); max 230 VAC: OUT1 – exceeding A1, OUT2 – exceeding A2 ( <i>upon exceeding A2, the active outputs are OUT1 and OUT2, with the exception of the 'window' detector</i> ), OUT3 – exceeding A3 ( <i>upon exceeding A3, the active outputs are OUT1, OUT2 and OUT3, with the exception of the 'window' detector</i> ); OUT3 can be configured via a function switch as an NC output, a fault (FLT) output, or an additional A2 output; 2 x 12V alarm outputs ( $\Sigma$ max 100mA) - A1 and A2 for controlling an external visual-audible alarm device; removable push-in terminal blocks = suitable for solid or stranded conductors (without the need for bootlace ferrules), with a cross-sectional area of 0.5 to 1.0 mm <sup>2</sup>
Indication visual	multicolour LED indicator: (green) = power supply/normal state and indication that the recommended calibration interval has been exceeded; (red) = A1, A2 or A3 alarm; (orange) = <i>detector fault, sensor module failure, or missing sensor module</i> ; (blue) = indicates reset, output test, output service lock-out, or momentary mode for sensor modules with periodic time-weighted average concentration calculations (TWA, STEL).
Audible indication	built-in sounder, 75 dB/1m (activated at A1 or A2, or disabled) - configured via a function switch
Electronic circuits	sensor presence monitoring, exceeded recommended calibration interval monitoring, event log
Dimensions, weight	153 x 110 x 60 mm (H, W, D); approx. 0.4 kg
Enclosure, IP rating	high-impact ABS/PC; 2-point mounting; IP54 for electronic circuits + IP44 for the splash-proof gas sensor cover ( <i>IP33 in WG-0E.Fx models</i> ) - only when the detector is in the recommended mounting position, i.e. with the cover pointing downwards!
Storage conditions	in a tightly sealed polyethylene bag, in a location free from moisture, dust, exhaust gases, vibrations, and devoid of any chemically active substances; storage temperature from -20°C to +50°C (WG- <i>nE</i> .Fx: -20°C to +25°C; however, for WG-9E5.Fx, the recommended range is 0°C to +20°C). WG- <i>nE</i> .Fx models (excluding WG-9E5.Fx): <b>calibration is required 6 months after the date of manufacture.</b>
Warranty	The Standard Gazex 3-Year Plus Warranty (SGG3Y+) covers the period until the end of the year of manufacture, plus an additional 3 years ( <i>year of manufacture is indicated on the rating plate =&gt; no warranty cards are issued</i> ); option to extend up to 5 years (RGG5Y+); sensor modules in WG/Fx units are covered by the Gazex Limited Warranty+ (OGG+)

### 3. VISUAL AND AUDIBLE INDICATION

**Table 3.1 – WG/Fx detector status indication**

STATUS	INDICATOR	INTERNAL SOUNDER	DESCRIPTION
<b>NORMAL</b> (GREEN INDICATOR)		none	sensor module (MS) <b>warm-up</b> for approx. 1 minute after powering on the detector (may vary depending on the MS type)
		none	<b>NORMAL</b> operating state, no alarms or faults
		none	<b>NORMAL</b> operating state, the recommended interval since the last calibration has elapsed
	<i>applies only to calculated alarm thresholds: 15 min / TWA / STEL</i>		
		none	<b>NORMAL</b> operating state, the momentary gas concentration exceeds the <b>A1</b> alarm threshold, but the alarm is not yet active green indicator – signals the normal state for approx. 5 s, then flashes – the number of flashes indicates: 1 – <b>A1</b> alarm threshold exceeded for the first gas only 2 – <b>A1</b> alarm threshold exceeded for the second gas only (*) 3 – <b>A1</b> alarm threshold exceeded for both gases (*) (*) – <i>applies to dual-gas detectors only</i>
<b>ALARM</b> (RED INDICATOR)		pulsing tone synchronised with the indicator	<b>ALARM1</b> , <b>A1</b> alarm threshold exceeded
		pulsing tone synchronised with the indicator	<b>ALARM2</b> , <b>A2</b> alarm threshold exceeded
		continuous tone	<b>ALARM3</b> , <b>A3</b> alarm threshold exceeded
	<i>applies to dual-gas detectors only</i>		
		tone synchronised with the alarm indicator	<b>ALARM</b> , red indicator – signals an active alarm state for approx. 5 s, then flashes – the number of flashes indicates: 1 – alarm threshold exceeded for the first gas only 2 – alarm threshold exceeded for the second gas only 3 – alarm threshold exceeded for both gases
<b>FAULT</b> (YELLOW INDICATOR)		none	<b>FAULT</b> , detector failure
		none	<b>FAULT</b> , yellow indicator – signals a fault state for approx. 5 s, then flashes – the number of flashes indicates the fault type: 1 – detector – incorrect power supply parameters 2 – MS – communication failure (missing MS or incorrect MS ( <i>with a white label</i> )) 3 – MS – failure
	 yellow - green	none	<b>FAULT</b> , MS re-warming following a communication interruption between the detector and the MS
	 yellow - red	tone synchronised with the alarm indicator	<b>FAULT</b> , during an active alarm state, red indicator – signals an active alarm state for approx. 5 s, then the yellow indicator flashes – the number of flashes indicates the fault type,
<b>SPECIAL</b> (BLUE INDICATOR)		tone synchronised with the alarm indicator	<b>OUTPUT TEST</b> , activation of selected alarm and fault states for 15 minutes, blue indicator – one flash per cycle, every approx. 5 s
		tone synchronised with the alarm indicator	<b>SERVICE MODE</b> , outputs are disabled for 15 minutes (the last output state of the detector is locked), blue indicator – two flashes per cycle, every approx. 5 s
	<i>applies only to calculated alarm thresholds: 15 min / TWA / STEL during the normal state</i>		
	 blue - green	tone synchronised with the alarm indicator	<b>MOMENTARY MODE</b> , detector is set to respond to momentary gas concentrations for 15 minutes blue indicator – three flashes per cycle, every approx. 5 s
<b>SYMBOL / MEANING</b>			
			
continuously illuminated	unlit	any active state	
			
pulses once per second	pulses 5 times per second	unlit, followed by a flash	pulses alternately

**Table 3.A.1 – internal sounder control settings via the DS1 ('SIREN') function switch**

Switch DS1	Configuration of the detector's internal sounder			
	NORMAL / FAULT	A1	A2	A3
	muted	muted	muted	muted
	muted	ACTIVE*	ACTIVE*	ACTIVE*
	muted	muted	ACTIVE*	ACTIVE*
	muted	ACTIVE*	ACTIVE*	ACTIVE*

\* - sounder active => the sounder emits a tone synchronised with the flashing of the red alarm indicator (as per Table 3.1.)

**3.A. OUTPUT FUNCTIONS**

**Table 3.A.2 – state of the voltage alarm outputs and contact outputs (does not apply to the 'window' detector).**

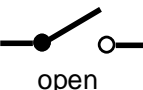
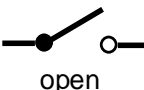
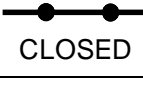
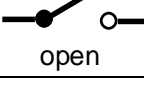
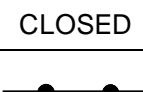
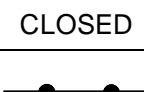
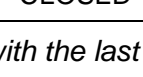
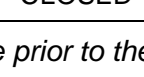
Detector state	Voltage outputs '(SL)'		Relay outputs			Internal sounder
	A1 terminals [08] - [10]	A2 terminals [8] - [11]	A1 terminals [03] - [04]	A2 terminals [05] - [06]	OUT3 terminals [07] - [08]	
<b>NORMAL</b>	voltage-free	voltage-free			Configuration via the DS2 switch	Configuration via the DS1 switch 'SIREN'
<b>A1</b>	Active (approx. 10.5V)	voltage-free				
<b>A2</b>	Active (approx. 10.5V)	Active (approx. 10.5V)				
<b>A3</b>	Active (approx. 10.5V)	Active (approx. 10.5V)				
<b>FAULT</b>	<i>in accordance with the last state prior to the FAULT activation</i>					

**Factory settings of the DS2 CONTACT OUTPUTS function switch – OUT3 output configured as FAULT ('FLT'), i.e. open during a FAULT or power failure.**

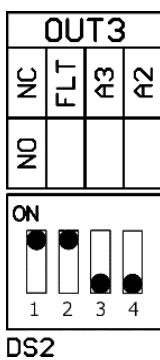
Switch DS2 (factory setting)	Configuration of the OUT3 contact output
	<p><b>Position 1: Selection of relay operating mode in the <u>inactive</u> state</b> – the detector is operating correctly and no alarm or fault states are active.</p> <p><b>DS2-1 (NO):</b> NO type output (contacts normally open in the NORMAL state);</p> <p><b>DS2-1 (NC):</b> NC type output (contacts normally closed in the NORMAL state) – <i>factory setting</i>.</p> <p><b>In the event of a power failure, the contacts are always open.</b></p>
	<p><b>Positions 2, 3, and 4: Selection of <u>activating</u> states</b> which will invert the output state relative to its inactive condition. Any combination can be enabled (logical OR – the output will trigger if at least one of the selected states occurs).</p> <p><b>DS2-2 (FLT):</b> Activation upon a detector fault – <i>factory setting</i>;</p> <p><b>DS2-3 (A3):</b> Activation upon exceeding the A3 alarm threshold;</p> <p><b>DS2-4 (A2):</b> Activation upon exceeding the A2 alarm threshold (duplicates the contact output in the A2 state)</p>

## 4. INSTALLATION CONDITIONS



The detector user and the INSTALLER must be aware of the specialised design and specific purpose of the WG detector.

This strictly requires all installation and maintenance work to be carried out with the **UTMOST DILIGENCE!!**



**4.1.** The INSTALLATION LOCATION of the detector in a room at risk of gas or vapour emissions **FUNDAMENTALLY** determines the correct operation of the Detector in terms of securing the premises. Therefore, determining the precise installation location must be entrusted to a qualified specialist.

In many cases, it can be assumed that the optimal installation location for the detector satisfies the following (**general requirements**):

- as close as possible to the potential source of gas emissions, no further than approx. **8 m** away (in horizontal projection),
- away from direct sunlight and free from strong electromagnetic fields (e.g., mobile phones),
- away from supply ventilation vents, windows, and doors,
- in an area not exposed to the direct impact of: outside air, water vapour, water or other liquids, cooking fumes, boiler exhaust gases, dust, mechanical shocks, or vibrations.

In the case of outdoor installation: under a canopy that provides protection against direct sunlight and the direct ingress of rainwater.

Furthermore (**specific conditions**):

**4.1.1.** For WG detectors calibrated for methane (natural gas, coke oven gas, biogas), acetylene, ethylene, and ammonia (lighter than air – accumulating in the upper sections of rooms):

- on a wall, **NO LOWER than 30 cm** below the ceiling, or directly on the ceiling
- ALWAYS above the upper edge of doors or windows!
- in an area NOT separated from the potential source of gas emissions by any structural element deeper than 30 cm (e.g., ceiling beams, coffered ceilings).

**4.1.2.** For WG detectors calibrated for propane, butane, pentane, hexane (or diesel, heating oil, or heavy fuel oil vapours), benzene, toluene (or other organic solvents), petrol, alcohols, hydrogen sulphide, or freons (significantly heavier than air – accumulating at the lowest levels of rooms):

- on a wall or mounting bracket, at a height **NO HIGHER than 30 cm** above the floor level
- NOT positioned over any floor depressions or pits
- in an area NOT separated from the potential source of gas emissions by steps, thresholds, or floor trenches

**4.1.3.** For WG detectors designed to detect hydrogen (extremely light, prone to 'chimneying' during high-volume emissions):

- directly above the potential emission source, positioned just below the ceiling;
- in rooms where lead-acid batteries are charged = **15 to 20 cm** below the ceiling.

**4.1.4.** For WG detectors calibrated for carbon monoxide (slightly lighter than air, easily mixes with air):

- on a wall, support column, or extension arm at a height of **approx. 180 to 200 cm** or higher;
- in locations where personnel are most frequently present or likely to pass;

**4.1.5.** For WG detectors calibrated for toxic gases at TWA or STEL levels, or for oxygen (workplace safety protection):

- on a wall, support column, or extension arm at the **breathing zone height of the working personnel**;
- as close to the workstation as possible, but always within the airflow arriving from the potential source of the toxic gas emissions;

**4.1.6.** For WG detectors designed to detect (CO<sub>2</sub>) (heavier than air, accumulates in the lower sections of rooms at high concentrations):

- on a wall or mounting bracket, at a height of **approx. 50 cm** above the floor level (for models intended to detect low CO<sub>2</sub> concentrations, i.e. A2<5000ppm – the height may be up at 180 cm);
- NOT in external draughts, and strictly outside the supply airflow from ventilation systems;
- outside the direct path of human exhalation (to prevent false alarms);
- in an area NOT separated from the potential source of gas emissions by steps, thresholds, or floor trenches.

The aforementioned distances from emission sources apply to zones of undisturbed diffusion, i.e. thermally homogeneous spaces free from mechanical obstructions restricting the flow of gases or vapours, without forced air circulation, and without natural ventilation. All of the above factors must be taken into account to ensure the correct placement of the detectors.



#### 4.2. MOUNTING POSITION: RECOMMENDED – VERTICAL, with the measuring chamber pointing downwards!

Horizontal mounting is permissible – with the cylindrical cover facing sideways – provided the detector is not exposed to moisture or other adverse factors, and the monitored room has a low dust level. Note that in this position, thermal compensation may not function correctly, and the detector loses its splash-proof rating.

#### MOUNTING POSITIONS:

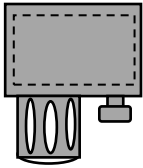

RECOMMENDED – vertical

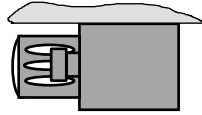

Permissible – horizontal (loss of splash-proof rating)

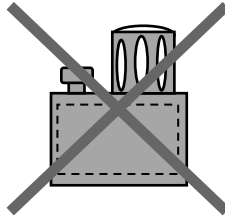
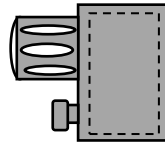

STRICTLY PROHIBITED:

### 5. INSTALLING THE WG/Fx



Installation and commissioning procedures for WG detectors and alarm devices powered by 230VAC mains voltage must only be carried out by competent personnel holding certified qualifications for working with electrical equipment supplied with hazardous voltages!



BEFORE installation, ensure that the detector is supplied with its individual **concise calibration certificate (SSW)** – the detector serial number stated must match the rating plate (whereas the sensor serial number on the SSW refers specifically to the sensor module, indicated by a barcode label on the sensor module pcb). The SSW certificate must be retained and strictly handed over to the end user, as it constitutes the prerequisite for processing any warranty claims.

5.1. Remove the detector's cover. Once removed, all subsequent tasks must be performed with the power supply disconnected. Do not remove or move the sensor module cover.

#### 5.1.1. Connecting CABLES:

Standard electrical installation cables with solid or stranded conductors may be used. The detector features spring-loaded push-in terminals that are highly resistant to vibration and contact material fatigue, ensuring totally secure connections. The method for wiring conductors to the terminal blocks is illustrated in Fig. 5.1.1.A.

#### Fig. 5.1.1.A Inserting a conductor into a removable push-in terminal block (straight type):

1. strip the conductor insulation to a precise length of 9 to 10 mm [1.];
2. for stranded conductors – lightly twist the exposed strands, depress the orange locking button [2.], push the conductor into the terminal hole as far as it will go [3.], and release the button [4.];

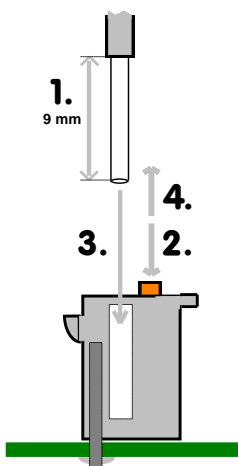

3. for solid conductors – manually or using pliers, simply push the stripped end into the round terminal hole as far as it will go [3.]. For the installer's convenience, solid conductors can be wired into the terminal blocks while they are detached from the header pins.

A correctly inserted conductor cannot be pulled out of the terminal block.

The conductor can only be released and removed by depressing the orange button [2.].

The two- and three-pole terminal blocks can be easily detached from the header pins, allowing individual detector circuits to be disconnected swiftly and easily. When pushing the terminal blocks back onto the pins, ensure the correct orientation and sequence are maintained.

The PE (protective earth) conductor must be left insulated and unconnected.



**WARNING:** prior to switching on the power supply, ALL terminal blocks must be securely fitted onto their respective pins – only in this state are the necessary clearance distances maintained to protect the installer from accidental electric shocks!!!



**5.1.2.** Cable ends should be prepared so that, once inserted into the terminal compartment, the conductors secured in the blocks do not need to be coiled inside the detector (due to varying lengths of the functional and PE conductors). The cable gland seal must grip the cable's outer sheath, and all stripped conductor sections must be fully concealed within the terminals (to mitigate the risk of electric shock).



**5.1.3.** Tighten the bottom cable gland to secure the power and control cable.

**IMPORTANT:** The cable must be tightened within the gland firmly enough to prevent it from slipping out when pulled by hand (and to ensure no mechanical strain is transferred to the detector's terminal connections). This ensures the detector remains properly sealed.

**5.2.** Mount the detector with the measuring chamber pointing downwards, ensuring the inlet to the sensor chamber is situated at the recommended height (depending on the type of target gas), in accordance with section 4.1. Use a minimum of two screws to secure the detector to the mounting surface. The detector must be installed in a way that allows unobstructed airflow around it. For installing WG detectors under non-standard conditions, the WSP-DG stainless steel mounting bracket may be used (*available separately from GAZEX*).

**5.2.1.** Care must be taken to ensure the detector is not subjected to mechanical damage/impacts, or to flooding by water or other liquids.



**FLOODING** the detector with water or other liquids will lead to the irreversible **DESTRUCTION** of the gas sensor! In such cases, replacing the sensor is **NOT** covered by the warranty!!

Furthermore, this creates a severe risk of electric shock!

Heavy impacts or mechanical vibrations can lead to irreversible changes within the sensor, and consequently compromise the detector's measurement parameters. In such instances as well, sensor replacement or calibration is **NOT** covered by the warranty!

**For installations in areas prone to mechanical damage, it is advisable to use an additional protective guard made of tubular profiles, such as the AR-1 manufactured by GAZEX, or a similar alternative.**

**5.3.** Where cables are routed through public or accessible areas (especially concerning LPG detectors), the use of plastic conduit is strongly recommended. This will protect the system against accidental or deliberate damage.

**WARNING, EXTREMELY IMPORTANT!!**



**Before energising the detection system**, it is absolutely essential to verify that the configuration of the output selection control terminals **IS CORRECT**.

**5.3.1.** Fasten the detector cover, ensuring the labels on the cover do not obstruct the indicator light.

**5.4.** Connect the 230VAC mains supply to the WG-...Fx (or 24VDC to the WG-...Fx/A). Connect the live conductor to the terminal marked '01' (or 'L'), and the neutral conductor to the terminal marked '02' (or 'N'). Leave the PE protective earth conductor unconnected. For the 24V version, conductor polarity is

irrelevant.



**WARNING:** The detector is not equipped with an isolator switch. The power supply must be routed via a suitable electrical isolator that disconnects both supply conductors.

**The WG alarm supply and control circuits** (contact outputs) **must strictly be protected using dedicated overcurrent circuit breakers!!!**



**WARNING:** Once the 230VAC voltage is engaged in the external power circuits of the gas detection system or the ventilation control circuits, **disconnecting the detector's terminal blocks will expose the header pins, which may carry a hazardous 230VAC mains voltage!!!**

Any wiring modifications to the detector must only be carried out after isolating all hazardous voltages from both the power supply and control circuits!!!

**5.4.1.** Once correctly powered, the detector's green indicator light will pulse (at 1 Hz) for approximately 1 minute (duration depends on the MS type) from the moment power is applied (during sensor warm-up). The outputs remain in their normal state. Following the warm-up period, the green indicator will remain continuously illuminated to denote the normal state (provided the gas concentration within the monitored area does not exceed the A1/A2/A3 threshold values!).

**5.4.2.** To verify the electrical connections of the control circuits, the output test procedure can be initiated by the detector. This is done by pressing the 'TEST' button or by holding a strong permanent magnet near the magnet symbol (the area marked 'TEST ZONE') on the bottom casing of the WG detector. To activate the magnetic test switch, any strongly magnetised object can be used, such as an interchangeable drill bit or a magnetised manual screwdriver tip. A miniature, dedicated, strong permanent magnet is also available from the detector Manufacturer (collection from the GAZEX head office or via post upon email request).

The 'TEST' button (whether internal or magnetic) functions independently of the presence of a sensor module within the detector.

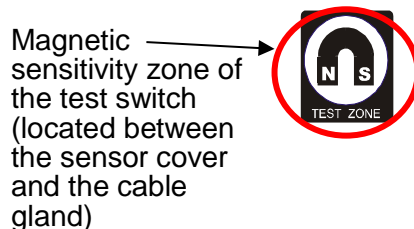

**5.4.3.** To initiate the output test procedure, press the internal 'TEST' button or trigger the magnetic switch externally. Correctly pressing and holding the button, or accurately positioning the magnet, is confirmed by brief flashes of the blue indicator light. The pulsing cycles are detailed in Table 5.1 below. Releasing the button or withdrawing the magnet during the second fast-pulsing cycle of the indicator (within 8-10 seconds of pressing) will initiate the test procedure on the outputs. Holding the button/magnet for an extended period (beyond the fast-pulsing phase) will progress to the next procedure. Once initiated, the output test procedure (indicated visually as per Table 5.1) sequentially generates states on the outputs in accordance with the description below the table.

**Table 5.1** – Functions triggered via the **TEST** button (or magnetically)

Function		RESET		TEST OUTPUTS		Mode SERVICE		Mode MOMENTARY	
<b>BLUE INDICATOR</b>									-
<b>Time [s]</b>	0 – 3	3 – 5	5-8	8-10	10-13	13-15	15-18	18-20	>20
<b>SYMBOL / MEANING</b>									
	 pulses 5 times per second				 flashes once per second				

**OUTPUT TEST** (pressing the 'TEST' button or holding a magnet within the magnetic sensitivity zone between the sensor cover and the bottom gland):

- **state** (output) triggering sequence:  
**ALARM1** (A1) » **ALARM2** (A1+A2) » **ALARM3** (A1+A2+OUT3\*) » **FAULT** (OUT3\*);
- upon activation, triggers the A1 state for 15 minutes,
- pressing the button (< 2 s) triggers the A1+A2 state for 15 minutes,
- pressing the button (< 2 s) triggers the A1+A2+A3 state for 15 minutes,
- pressing the button (< 2 s) triggers the FAULT state for 15 minutes,
- pressing the button (< 2 s) terminates the output test,
- the output test automatically concludes after 15 minutes in the last selected state,
- the test can be aborted at any point via the RESET function.

Detector **SERVICE mode**:

- locks the current output state and prevents OUT3 configuration changes for 15 minutes,
- the lock-out does not affect the internal sounder,
- automatically initiates the momentary mode,
- the mode can be exited at any point via the RESET function.

**MOMENTARY** gas response **mode**:

- only available for MS units featuring calculated thresholds (s15, TWA, STEL);
- triggered automatically upon powering up the detector;
- the detector responds to momentary gas concentrations automatically for 15 minutes from the moment power is applied;
- the momentary mode can be exited at any point via the RESET function.

**5.5.** The final stage of the installation process is the conclusive WG operational check:

**5.5.1.** Ensure the detector has been correctly powered for a **minimum of 15 minutes**. During this period, following power-on, the detector's sensor may exhibit significantly reduced sensitivity and its metrological parameters will be limited. This time allowance is mandatory prior to conducting any gas testing!

**5.5.2.** Generate the detector's alarm states:

Using a TC2-DG type test cap, apply the test gas at a flow rate of approx. 0.5 l/min. The type of test gas should match the description in the calibration certificate of the given detector, and its concentration should be at least 10% LEL higher than the tested alarm threshold (for explosive media) or at least 20% higher than the A2 alarm threshold value (for toxic, low-concentration media).

After several dozen seconds, the corresponding alarm state should be observed on the WG detector.

Testing of low-concentration toxic gas detectors, e.g. WG-22.Fx and WG-nE.Fx (calibrated to TWA/STEL), should be carried out within the first 15 minutes after power-up – these detectors initially start in a mode reacting to instantaneous test gas concentrations (alarm thresholds are not triggered based on the calculated time-weighted average concentration values 's15' and TWA/STEL), which facilitates testing. Once the initial 15-minute period has elapsed, the detector automatically switches to a mode reacting to the calculated time-weighted average CO concentration values = test activation of individual alarm thresholds can be time-consuming (high test gas consumption)!

 **NOTE:** the detector's operation in the instantaneous test mode (without average calculation) can be forced at any time.

**To activate the INSTANTANEOUS test mode of the sensor** – press the internal 'TEST' button or trigger the magnetic switch from the outside. Correct pressing and holding of the button or proper application of the magnet is confirmed by the green indicator light changing to a flashing blue state (every 1 second). The button must be kept pressed or the magnetic switch kept active – until the availability of the sensor's instantaneous mode is indicated - rapid pulsing of the indicator light (after 18 seconds, according to Table 5.1.) signals that **the INSTANTANEOUS mode** can be activated (rapid pulsing at 5Hz); when the TEST button is released (or the magnet is moved away from the rating plate) during the fourth 'rapid pulse', the sensor's INSTANTANEOUS mode is activated. Holding the button/magnet longer (beyond the indicated fourth 'rapid pulse') cancels the test procedures (after releasing the button, the pulsing indicator light changes to a steady green).

**The activated INSTANTANEOUS mode is indicated by 3 short flashes of the blue light repeated every 5 seconds.**

**By applying appropriate test gas mixtures, it is possible to verify the threshold concentrations at which the detector responds. The return to normal operation (the green light illuminates permanently) occurs automatically 15 minutes after entering the sensor's instantaneous test mode. The transition to normal operation (with active calculation of average values) can be accelerated at any time by performing the RESET procedure (according to Table 5.1.).**

Testing of a detector with a catalytic sensor can be carried out using a test gas other than the calibration gas, provided that the values of the sensitivity coefficients of the calibration and test gases (from Table 1.2.nK) do not differ by more than 50%, and the calculated relative concentration does not exceed the measuring range of the tested detector.



Testing of a detector with an electrochemical sensor may solely be carried out using a calibration test gas with a concentration greater than the arithmetic mean of the A2 and A1 levels but less than 50% of the short-term exposure limit value (column 8 of Table 1.1.B). It is permissible to use a test gas for which the value of the sensitivity coefficient relative to the calibration gas (from Table 1.2.WGF.nE) is greater than +5%, and the calculated relative concentration does not exceed the measuring range of the tested detector.

**5.5.3.** Testing the detector with gases of undetermined/incorrect concentration may lead to temporary or permanent damage to the sensor or necessitate recalibration (**which is NOT covered by the WARRANTY!**).

Upon a positive test result  
**The WG detector can be considered operational and commissioned.**

**Note:**

A detector with a semiconductor sensor achieves full measuring capability after a minimum of 24 hours of uninterrupted power supply!!!

The WG-9E5.Fx detector with an electrochemical sensor is sensitive even to a momentary power loss and may subsequently overestimate oxygen concentration readings – returning to proper operation can take up to 2 hours.

A detector with a catalytic sensor achieves measuring capability after at least 1 minute of uninterrupted power supply.

A detector with an optical (Infrared) sensor achieves full measuring capability after at least 15 minutes of uninterrupted power supply.

The date and the name of the installer, along with the serial numbers of all detectors installed in the System, must be recorded in the Periodic Inspection Report. The abridged calibration certificate (SSW) should be kept together with the Report.

In case of any lack of clarity or doubts regarding the installation and operation of the DETECTOR, please contact the Service Partner or the MANUFACTURER.

## 6. MAINTENANCE / OPERATION

**6.1.** Due to the high durability of the WG detector components, maintenance is limited to:

- A)** periodically removing dust from the sensor cover and optionally (after dismantling the cover) clearing its openings by blowing them out with compressed air,
- B)** periodically inspecting the system's operation according to the procedures in chapter 5.5. of this manual.

*Recommended frequency of periodic inspection*  
no less frequently than **every 3 MONTHS** (see below - **NOTE 6.6.**)

Inspection according to procedure 5.5. is also mandatory each time system power is restored after an interruption longer than 3 days (does not apply to WG-nKL.Fx and WG-nR.Fx models) and after the occurrence or suspected occurrence of gas concentrations exceeding the values according to Tables 1.1... column 8.

**C)** - in the event of high humidity in the monitored room or exposure of the connection cable or the detector itself to water splashing, the above procedure must be supplemented with a leak tightness inspection of the detector's cable gland:

- - switch off the power supply to the detector (system), wait 10 minutes, verify the absence of an explosive gas atmosphere around the detector,
- - remove the detector cover,
- - check if the terminal chamber or connector terminals are damp, covered in residue, or show signs of corrosion. In such a case, it is **IMPERATIVE** to dry the terminal chamber, seal the cable gland (tighten), and ensure the removal of water drops from in front of the gland (flanges, cable sleeves, a "U" drip loop on the cable before the gland, etc.).
- - fit the cover,
- - carry out an inspection according to the procedure in chapter 5.5.



**6.1.1.** Since catalytic and electrochemical gas sensors have a natural tendency to decrease in sensitivity over time, it is necessary to systematically inspect and calibrate detectors equipped with such sensors. Recommended calibration interval: according to Table 1.1... The aforementioned activity can be performed for a fee by the Manufacturer or a Service Partner upon delivery of the MS sensor module removed from the detector to the above-mentioned entities.

Calibration may also be necessary **every time** factors disrupting the gas sensor's operation occur (Tables 2.1...). In this case, it may be necessary to replace the sensor – a paid service provided by the Manufacturer!

Since a semiconductor gas sensor may have a natural tendency to increase in sensitivity over time, after approximately 3 years of operation, an excessive lowering of the alarm thresholds may occur (see Technical Parameters - long-term stability). This does not alter the detector's operating principles; nevertheless, it is recommended (especially when the User notes frequent system responses to relatively low gas concentrations) to perform calibration, i.e., correction of the alarm level settings,

**no less frequently than every 3 years of the detector's operation.**



**6.1.1.A** The elapsing of the recommended interval for the next calibration of each sensor is indicated on the WG detector only optically (*no response at the outputs, while maintaining full alarm functionality*) by rapid (5Hz) pulsing of the green indicator light (see Table 3.1. – NORMAL

STATE).

Calibration can be carried out by the Manufacturer or a Service Partner on-site or upon delivery of the MS sensor module to the above-mentioned entities.



**Applying the WpW procedure (Calibration by Replacement, available for selected MS types), i.e.**

**- ordering a newly calibrated MS sensor module of the appropriate type via the Manufacturer's website;**  
**- replacement of the old MS with the new one by the User;**  
**- returning the old MS to the Manufacturer,**  
**seems to be the fastest and most economically justified method of maintaining the detector's full operational capability.**

**6.1.2.** If the detector(s) must remain in a gas atmosphere with a concentration exceeding any of the 'Short-term exposure limit' values according to Tables 1.1... (column 8) or if a concentration above the A2 threshold persists for a long time = the system **MUST BE SWITCHED OFF**, i.e. disconnect the mains power supply and disconnect the backup power supply battery (if connected), and cover the sensor enclosure on the detector(s) in a gas-tight manner with a polythene bag. Before switching it back on, ensure that the concentration has dropped below the A2 threshold and remove the bag.



**6.1.3. NOTE:** ALL periodic inspection results, noticed irregularities in the detection system's functioning, system power interruptions, and the fact that detectors operate in extreme conditions must be strictly recorded in the **Periodic Inspection Report** under the penalty of voiding the warranty.

## 6.2. IMPORTANT:

Maintaining the gas permeability of the sensor cover is of **FUNDAMENTAL** importance for the CORRECT operation of the Detector!

**6.2.1.** Removing the gas sensor cover:

- switch off the power supply to the detector (mandatory!, for systems with backup power = switch off the power supply unit and DISCONNECT THE BATTERY!);
- ensure there is no explosive gas atmosphere near the detector!
- remove the cylindrical sensor cover:
  - partially unscrew the cover locking screw (do not unscrew it completely – the screw positions the inner cover relative to the outer one);
  - gently rotate the cover partially anticlockwise, pull the sensor cover downwards to remove it.



## 6.2.2 REPLACEMENT OF THE MS SENSOR MODULE

### NOTE!

The procedure for removing the cylindrical sensor cover must be carried out with the utmost care so as not to damage the gas sensor.

6.2.3. The procedure to be followed when removing the sensor module for replacement or returning it for calibration:

- a) remove the detector cover according to 6.2.1.;
- b) unscrew the screw securing the sensor module to the spacer sleeve (if the screw is seized, hold the sleeve with pliers);
- c) gripping the edges of the insulating board, disconnect the sensor module from the connection socket (DO NOT pull on or touch the gas sensor!!!);
- d) place the board with the sensor (along with any filler insert) into a tight polythene bag or container, and close it tightly;
- e) a severe mechanical shock (e.g. dropping onto a hard surface) may permanently damage the gas sensor!
- f) place it in a box lined with soft foam to protect against shocks;
- g) refit the sensor cover, DO NOT switch on the power supply to the detector until the new sensor module is installed;
- h) NOTE: if power is connected to a detector with its sensor module removed – the detector's FAULT signalling is activated;
- i) protect the detector against splashes, dust, or dirt.

6.2.4. Procedure for installing the MS sensor module (with power switched off!):

- j) remove the sensor cover;
- k) NOTE! – a severe mechanical shock (e.g. dropping onto a hard surface) may permanently damage the gas sensor!!!
- l) gripping the edges of the sensor module, very gently connect the module to the connection socket (DO NOT touch the gas sensor!!!) so that all connectors fit into the socket;
- m) drive in the screw securing the sensor board to the spacer sleeve (do not use excessive force!);
- n) slide on the sensor cover (ensure correct alignment of the inner and outer covers – the top edges must align) and gently rotate the cover partially (clockwise) until resistance is felt;
- o) tighten the screw locking the cover to the housing.

After fitting the cylindrical cover, replace the yellow calibration plate with a new one (supplied with the new sensor module).

6.3. Spare parts available for the WG/Fx detector:

- a) MS sensor module (with 3-threshold calibration for a specific medium);
- b) sensor cover (two-part) with a locking screw.

## 6.4. STORING THE WG DETECTOR



WG/Fx detectors must be stored in a place free from tremors, vibrations, moisture, dust, exhaust fumes, and free from any chemically active substances (especially those containing silicones and their derivatives), in a tightly sealed polythene bag.

Long-term storage temperature: from -20°C to +50°C (exception - models with an electrochemical sensor WG-nE.Fx from -20°C to 25°C).

The WG detector must always be stored with the attached SSW calibration certificate.

Once the storage period has been exceeded (counting from the date of manufacture or dispatch from the manufacturer's warehouse):

- 6 months – for detectors with an electrochemical sensor;
- 12 months – for detectors with a catalytic sensor;
- 36 months – for detectors with a semiconductor or optical Infrared sensor,

it is recommended to perform recalibration.

## 6.5. NOTE:

Due to the continuous product improvement process and the desire to provide the most complete, detailed information about these products, as well as to pass on the knowledge necessary for correct, long-term product operation based on Customers' previous experiences, the GAZEX company reserves the right to introduce minor changes to the technical specifications of the supplied products that are not included in this User Manual, and to make changes to the content of the manual. Therefore, please verify and confirm the validity of the version of the User Manual you possess with the Manufacturer (please state the exact type and series of the device used, as well as the manual's edition number – from the document's footer).

6.6. **NOTE:**

**THE FREQUENCY OF PERIODIC INSPECTIONS OF THE WG gas detection SYSTEM** should depend on the system's operating conditions, the type of detectors used, and the level of importance of the system/facility in the User's opinion:

- 1) Carrying out a **PERIODIC SYSTEM INSPECTION** is recommended **after every sensor module replacement or calibration of any detector** in the system (the frequency depends on the calibration interval recommended in the technical parameters of the specific detector models);
- 2) and furthermore:
- A. **Recommended** frequency of periodic **SYSTEM inspection every 3 months** -
- applies to systems with detectors operating in rooms with significant dust, high humidity, where a background gas level is frequently present, and
  - applies to extensive systems containing a large number of detectors;
- B. **Normal** frequency of periodic **SYSTEM inspection every 6 months** –
- applies to systems with detectors operating in averagely stable conditions, without exposure to the constant presence of a background gas level, and
  - applies to systems controlling gas valves;
- C. **Reduced** frequency of periodic **SYSTEM inspection every 12 months** –
- applies to systems with detectors operating in a normally clean atmosphere and in stable conditions, and
  - applies to systems containing a small number of detectors/devices.

A Periodic System Inspection must also be carried out EACH TIME specific conditions occur in the detection system's operation, i.e.:

- the periodic occurrence of extreme operating conditions for the detectors, e.g. high gas concentration (over 50% LEL or over 75% of the short-term exposure limit or measuring range), extremely high or very low temperatures (near the limits of the recommended operating temperature range), high periodic dustiness, or a sustained increase in humidity (at the condensation limit);
- the presence of high concentrations of gases other than the calibration gas, the presence of which was not anticipated in the monitored zone;
- prolonged operation with the A2 alarm state activated;
- after a system power interruption lasting longer than approximately 3 days (does not apply to WG-nKL/N models);
- after the occurrence of overvoltages or severe disturbances in the electrical installation;
- after carrying out renovation or installation work that may affect the system's functioning or configuration (e.g. painting; floor maintenance; changing the number, layout, or power supply method of the system devices, etc.).



**NOTE:** The above-mentioned System inspection frequency can be considered to comply with good engineering practice, based on the Manufacturer's over 30 years of experience. However, it should be noted that in the specific conditions of a particular Customer, this frequency **may be subject to modification**, adopting the principle that the more important the system is (from the Customer's/User's point of view) – i.e. the more the Customer cares about the efficient, fault-free operation of the facility of which the system is a part – the more frequently the system in question should be inspected. When expecting an increased level of operational safety of the facility, the Customer should conduct detection system inspections more frequently, e.g. every 4 weeks or before any event/measurement important to them. Conversely, by assessing the role of the detection system as less significant or relying on their own reliability assessment of the facility's components, the Customer/User may decide to extend the detection system inspection interval, e.g. to 6 or 12 months.

**THE SYSTEM INSPECTION INTERVAL MUST NOT EXCEED 12 MONTHS!**

6.7. In accordance with the Act of 11 September 2015 on waste electrical and electronic equipment, a used detector must not be disposed of together with other household waste. It must be taken to a designated waste collection point. Therefore, it is marked with a special symbol:

Proper disposal protects against the negative impact of waste on health and the human environment.



## 7. WARRANTY TERMS AND CONDITIONS

The device is covered by the Gazex Standard 3-year plus Warranty (SGG3Y+) in Poland in accordance with the SGG3Y+ terms and conditions available at [www.gazex.pl](http://www.gazex.pl). Selected excerpts from the SGG3Y+ terms and conditions:

- ...
1. The GAZEX company guarantees the proper operation of devices of its own production for the period until the end of the year in which the device was manufactured and for the subsequent 3 years.
    - 1.1 The year of manufacture is taken from the device's rating plate (*warranty cards are not issued!*).
    - 1.2 If the rating plate is illegible – the year of manufacture is determined based on the serial number or barcode labels on the subassemblies (*if such labels are present*) together with records in the GAZEX electronic production supervision system. Such verification is subject to a fee. The verification fee is PLN 50 net for each commenced verification of a batch of up to 10 devices.
    - 1.3 Unidentifiable devices, i.e. with a damaged/illegible rating plate or lack thereof, and with the GAZEX logotype permanently removed/covered, will not be covered by warranty service.
    - 1.4 The SGG3Y+ warranty covers all devices manufactured by GAZEX after 1 January 2021, which feature the production year '2021' or later on their rating plate.
  4. The warranty does not cover damage caused by:
    - a) shocks, vibrations and mechanical impacts, thermal impacts, and the effects of chemical substances;
    - b) damage resulting from improper storage, faulty installation, or incorrect operating conditions contrary to the device's User Manual;
    - c) failure to perform periodic maintenance activities or other forms of negligence;
    - d) deliberate actions by the user, third parties, or persons unauthorised to carry out repairs;
    - e) lightning strikes, power grid overvoltages, or electrostatic discharges;
    - f) force majeure or other events beyond the Manufacturer's control.The warranty does not cover consumables, including but not limited to fuses, batteries, built-in accumulators, gas sensors (which are covered by the GAZEX Limited Warranty OGG+), and components with porous sinters.
  6. Warranty rights expire in the following cases:
    - a) damage to factory seals, service seals, or marks identifying the device/components;
    - b) interference with the internal circuits of the device or the introduction of any other changes to the device or control program, or when the device operates with non-original components not originating from GAZEX;
    - c) failure to perform periodic maintenance activities, confirmed by systematic records in the Periodic Inspection Report (attached to the device or to the devices cooperating with it), which are required in the device's User Manual.

...  
*The full text of the SGG3Y+ terms and conditions is available at [www.gazex.pl](http://www.gazex.pl).*

FAILURE to comply with all the conditions for the installation and operation of the detector described in this Manual (including maintaining the Periodic Inspection Report, available in 'pdf' format, available at: [www.gazex.pl](http://www.gazex.pl)) will result in the loss of warranty rights.

It is possible to extend the warranty up to 5 years - Gazex Extended 5-year plus Warranty (RGG5Y+), in accordance with the RGG5Y+ terms and conditions available at [www.gazex.pl](http://www.gazex.pl).

MS sensor modules in WG/Fx detectors are covered by the GAZEX Limited plus Warranty (OGG+) for a period of:  
- **3 months** from the date of sale on the invoice, but no longer than **6 months** from the date of production/packaging – MS with electrochemical sensors;  
- **12 months** from the date of sale on the invoice, but no longer than **18 months** from the date of production/packaging – MS with semiconductor, catalytic, or optical Infrared sensors.

If the date of sale cannot be determined or verified, the packaging/dispatch date or the calibration date on the Abridged Calibration Certificate (SSW) is taken as the beginning of the warranty period, in accordance with the OGG+ terms and conditions published at [www.gazex.pl](http://www.gazex.pl).

*The full text of the SGG3Y+ terms and conditions is available at [www.gazex.pl](http://www.gazex.pl).*

FAILURE to comply with all the conditions for the installation and operation of the detector described in this Manual (including maintaining the Periodic Inspection Report) will result in the loss of warranty rights. A sample version of the Periodic Inspection Report is available in 'pdf' format at: [www.gazex.pl](http://www.gazex.pl)

### NOTE:

All complaints require the registration of a warranty repair request or a post-warranty repair request on the portal: <https://www.gazex.com/pl/serwis>

It is possible to extend the warranty up to 5 years - Gazex Extended 5-year plus Warranty (RGG5Y+), in accordance with the RGG5Y+ terms and conditions available at [www.gazex.pl](http://www.gazex.pl)