



Warsaw

USER MANUAL

Edition: 3aW4W5W6

DG.EN/M

An economical, threshold gas detector, with digital communication (addressable), featuring a REPLACEABLE, intelligent semiconductor or optical (Infra-Red) SENSOR

[W4], [W5], [W6] series

BEFORE installing, read the USER MANUAL in its entirety.

Proceed only if you have fully understood this manual.

Keep this manual for reference by the User of the gas detection system.



1.	Intended use, features, description	p. 2
2.	Technical parameters	6
3.	Connecting DG.EN/M in DGDS	7
4.	Installation conditions	9
5.	DG.EN/M installation	10
6.	Maintenance/operation	14
	Sensor module replacement	15
7.	Warranty terms and conditions	16

PRODUCER:

gazex

GAZEX

Baletowa 16, PL 02-867 Warsaw, POLAND

Tel: +48 22 644 2511 gazex@gazex.pl

www.gazex.com

©gazex '2024. All rights reserved. Reproduction or copying, in whole or in part, without the permission of GAZEX is prohibited. The 'GAZEX' logo and the 'gazex' name, as well as 'dex', 'Aktywny System Bezpieczeństwa Instalacji Gazowej' [Active Gas Installation Safety System], ASBIG, are registered trademarks of GAZEX company.

Work and Live SAFER with Us!

©gazex

1. INTENDED USE

The **DG.EN/M** economical detectors are designed for use in Digital Gas Detection Systems (DGDSs) that operate in a network with RS-485 communication and the MODBUS RTU protocol. In the remainder of this manual, the Digital Gas Detection System will be referred to as the 'System'.

APPLICATION:

- Industrial facilities, logistics centres, public utility buildings;
- Large spaces at risk of specified toxic or explosive gas emissions;
- Hotels with distributed air conditioning systems;
- GARAGES and underground parking facilities – controlling ventilation and warning of LPG/CNG leaks or CO presence.

FEATURES

- Communication, control and transfer of information through the RS-485 port with MODBUS RTU protocol;
- Remote monitoring, identification, and diagnostics of all detectors in the network;
- Selective, averaged measurement of carbon monoxide concentration or threshold detection of explosive gases, refrigerants, and carbon dioxide;
- Sensors in REPLACEABLE, intelligent modules;
- Built-in microprocessor controller = reliability, operational stability, thermal compensation system, semi-automatic network addressing (easy setup), alarm status testing without gas mixtures, alarm status history (*available only from the Manufacturer*);
- 3 gas concentration alarm thresholds;
- Selective optical signalling;
- 2 cable glands – easy serial connection of additional detectors;
- Built-in semi-automatic procedure for addressing detectors in the network – easy system startup;
- Connection status monitoring – indication of proper digital communication;
- Optical signalling of alarm and fault statuses of the detector;
- Ability to perform output signal tests (without the need for a gas mixture);
- Three operating modes: with alarm memory (default), without alarm memory, and with alarm hold;
- Adjustable alarm activation and deactivation delay times;
- Changing operating modes, delay times, address assignment or change using DETnet View 1.2 software (or higher); (current software version available at www.gazex.pl);
- Multifunctional button inside the enclosure (address confirmation, test triggering, clearing alarm and fault information, and possible address reset);
- Button functions accessible without removing the enclosure by applying a magnet to the area marked 'TEST' with a magnet symbol;
- Robust, splash-proof enclosure with high-impact ABS.

DESCRIPTION OF THE DETECTOR

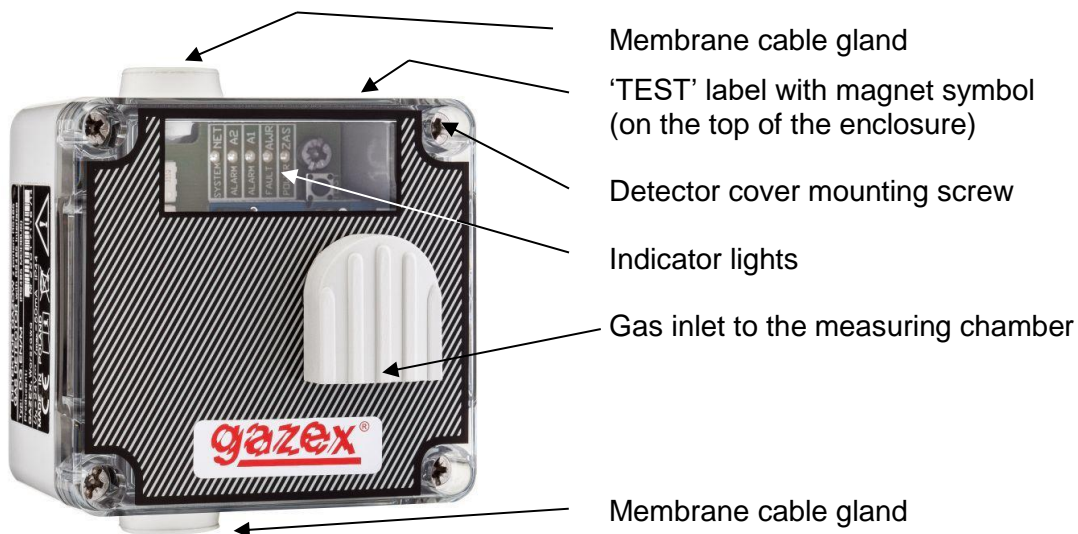

Fig.1.1. View of DG.EN/M in the recommended mounting position.

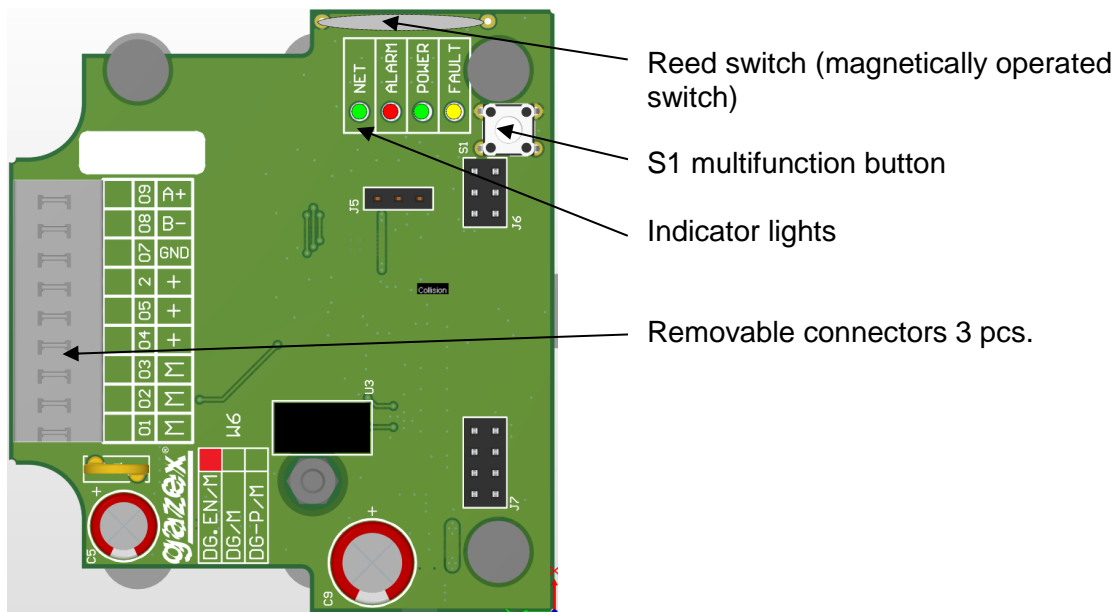

Fig. 3.2. View of the DG.EN/M internal base plate

TABLE 1.1. DG.EN/M visual signalling

Indicator / Function	RED (ALARM)	GREEN (POWER)	YELLOW (FAULT)	GREEN (NET)
Faulty processor / no program	off	off	steady on	off
Low power supply (power failure)	off	off	1 blink	-
No sensor module (detector line failure) and no power failure	off	off	2 blinks	-
Sensor module failure and no power failure	off	off	2 blinks	-
No address and no detector line failure, sensor module (MS) failure, or power failure	off	off	alternates with NET lamp	flashes quickly
Detector responded to a query	-	-	-	short flashes
Addressing mode	off	off	off	flashes very quickly
Detector off	off	flashes in 1s/3s cycle	off	-
Normal status, sensor module warm-up after power on, and address set	off	flashes slowly	off	-
Normal status	off	steady on	off	-
Normal status, sensor module calibration recommended	off	flashes quickly	off	-
Alarm 1	flashes slowly	off	off	-
Alarm 2	flashes quickly	off	off	-
Alarm 3 (measurement version only)	steady on	off	off	-
User-initiated test	test	flashes in 0.1s/0.9s cycle	test	test

A 1s/3s flashing cycle means the light is on for one second and then off for three seconds.

Flashing of the lights: slow – frequency of 1 Hz (the light status changes every 0.5 s); fast – frequency of 2.5 Hz (the light status changes every 0.2 s); very fast – frequency of 5 Hz (the light status changes every 0.1 s).

If you observe any effects different from those mentioned above, please contact the Authorised Distributor or Manufacturer.

TABLE 1.2. Functions of the multifunction button [S1] and the magnetic switch (externally actuated by a magnet):

Function	Assigning an address (in addressing mode) or displaying the address (normal mode)	reset	-	System output test	-	Address deletion (possible within 3 minutes of power-on)	-
Indicator POWER	flashes slowly	flashes very quickly	flashes slowly	flashes very quickly	flashes slowly	flashes very quickly	-
Time [s]	0.1 to 3	3 to 5	5 to 8	8 to 10	10 to 20	20 to 22	>20

Flashing of the lights: slow – frequency of 1 Hz (the light status changes every 0.5 s); fast – frequency of 2.5 Hz (the light status changes every 0.2 s); very fast – frequency of 5 Hz (the light status changes every 0.1 s).

After initiating the Output Test sequence, the following output status changes will be generated sequentially (for 20-second periods) (in the supervisory module):

OUT1 (A1) → OUT2 (A2) → OUT3 (A3) → OUT4 (AWARIA).

The functions of the S1 button depend on the detector mode (normal operation or address mode) and on how long the button is pressed.

In addressing mode, after pressing the button briefly (longer than 0.1 s but shorter than 3 s), the detector saves the address sent by the MDD-256/T supervisor module (or DETnet View software) and exits addressing mode.

In normal operation mode, after pressing the button briefly, the detector's 3-digit network address (between 0 and 255) will sequentially display (from 0÷255) by flashing the NET lamp:

- The NET lamp goes out for 1 s;
- Next, the NET lamp will indicate the hundreds digit of the address number with blinks: one long blink (approx. 0.5 s) = 0 hundreds in the address number; one short blink (0.1 s) = 1 hundred in the address number; two short blinks = 2 hundreds in the address number.
- The NET lamp goes out for 1 s;
- Next, the NET lamp will indicate the tens digit of the address number with blinks: one long blink = 0 or the number of short blinks = the tens digit in the address number;
- The NET lamp goes out for 1 s;
- Next, the NET lamp will indicate the units digit of the address number with blinks: one long blink = 0 or the number of short blinks = the units digit in the address number.

DG.EN/M MODEL RANGE

The DG-*nn*.EN/M detector series with semiconductor sensors and IR optical sensor includes the following models:

TABLE 1.3.nn

SYMBOL		Concentration range							Calibration PERIOD		service life in clean air about [years]
Model	Sensor model MS-...	gas / medium	concentration range + selectivity	A1 min value (recommended)	A2 max value (recommended)	allowed temporarily (<1min/30min)	STANDARD CALIBRATION** A1/A2/A3	unit	recommended max [months]	optimal [months]	
1	3	4	5	6	7	8	8A	9	10	11*	12
DG-11.EN/M	11.EG	methane	W	10	40	100	10/30/(50) (p2)	%LEL	36	12	10
DG-14.EN/M	14.EG	methane (selective)	W+SL	10	40	100	10/30/(50) (p2)	%LEL	36	12	10
DG-15.EN/M	15.EG	propane-butane	W+SL	10	40	100	10/30/(50) (p2)	%LEL	36	12	10
DG-22.EN/M	22.EG	carbon monoxide	N+SL	20	1,000	2,000	~20 /100 (s15), A3>250ppm (p2)	ppm	36	12	10
DG-61.EN/M	61.EG	HFC (Freons)***	W	500	3,000	10,000	1,000/2,000/2,500 (p2)	ppm	12	12	10
DG-73.EN/M	73.EG	hydrogen (selective)	W+SL	10	40	100	10/30/(50) (p2)	%LEL	36	12	10
DG-8R8.EN/M	8R8.EG	CO2 (selective IR)	SL	600	3,000	10,000	1,000/1,400/1,800 (p2)	ppm	36	12	15

*- calibration is also recommended before each important measurement/event relevant for the user;

**- A1/A2/A3 values: (s15) = average value over the last 15 minutes, (p2) = instantaneous concentration value;

*** - standard for Freon R410 or R32;

Concentration range marking: SL - increased selectivity,

N – concentrations considered low in metrological practice, S – medium, W – high.

ATTENTION – IMPORTANT INFORMATION:



- The sensor used in the detector is resistant to **temporary** increases in the concentration of substances listed in Table 1.3, column 7. However, prolonged operation of the detector (regardless of type) in conditions where gas concentrations exceed the value in column 7 is **UNACCEPTABLE** for all the media listed in the table! This may result in a permanent change in the detector's measurement parameters or complete damage to the gas sensor.

- It is **NOT** recommended to operate the detector for extended periods in concentrations above approximately 3 to 5% LEL for explosive gases or above the A1 threshold concentration of a detector calibrated for toxic gases – this may cause the effects described above.
- The use of gases with uncontrolled concentrations for testing the detector's operation is **NOT** permitted!

2. TECHNICAL PARAMETERS

Model	DG- <i>nn</i> .EN/M, DG-8R8.EN/M
Supply voltage / range	24 VDC / acceptable range: 10.0 to 30.0 V
Power consumption (current)	max 1.2 W / max 50 mA@24V
Operating temperature	-10°C to +45°C recommended, periodically allowable: -20°C to +50°C (<1h/24h)
Air Humidity:	30% to 90% RH (relative)
Gas sensors	Semiconductor with carbon filter (models DG-22.EN/M and DG-14.EN/M), japanese-made; housed in a REPLACEABLE module; estimated service life in clean air – approx. 10 years;
Detectable gases	DG-22.EN/M: CO, range 20 to 1,000 ppm (1 %vol. =10,000 ppm); DG-11.EN/M: methane, range 5 to 40 %LEL; DG-14.EN/M: methane, range 5 to 40 %LEL (increased selectivity!); DG-15.EN/M: propane-butane: range 5 to 40 %LEL; DG-61.EN/M: HFC(freons), range approx. 500 to 3,000 ppm DG-73.EN/M: hydrogen, range 5 to 40 %LEL; DG-8R8.EN/M: CO2, range 400 to 5,000 ppm;
Measurement method	Diffusive ('Tg3' gas permeability class of the sensor cover [according to GAZEX classification]), cyclical every 1 to 10 s (depending on model)
Alarm Thresholds	three, A1, A2, A3
Threshold concentration values standard (or within the above range)	14: A1 = 10%, A2 = 30 %, A3 ≈ (50)* % LEL for methane (selective); 15: A1 = 10%, A2 = 30 %, A3 ≈ (50)* % LEL for propane-butane; 22: A1 = 30 ppm, A2 = 60 ppm – average value of concentration of CO for 15 min., A3 = 150 ppm CO for >1 min. (under PN-EN 50545-1); 61: A1= 1,000, A2= 2,000, A3=2,500 ppm R410A or R32 (or by order) 73: A1 = 10 %, A2 = 20 %, A3 = 30 % LEL for hydrogen (selective); 8R8: A1= 1,000, A2= 1,400, A3= 1,800 ppm CO2
Threshold Accuracy	Relative error ≤ ±20% for A2 under calibration conditions: 20(-2/+5)°C, 65(±10)%RH, 1013(±30) hPa, >72 h continuous power supply
Thermal stability of thresholds	± 15 % in the range 0°C to 40°C
Long-term stability	± 20 % / year but not lower than ± 30% over a period of 3 years
Calibration period	Recommended: < 36 months; Optimal = 12 months
Optical signalling	LED lights – ALARM = red, AWR = yellow, ZAS = power and NET system = green; selective signalling, i.e., only one light is illuminated at a time in the specified colour
acoustic:	none
System communication	RS-485 port, galvanically isolated from power (up to 1,000 VDC)
Communication parameters	9600 Baud, Even, 8, 1, response time below 100 ms, MODBUS RTU protocol
Output test signal	Manually triggered by the 'S1' button under the cover or by applying a magnet to the designated spot on the enclosure
Number of detectors per branch	max 224 units
Dimensions	82 x 95 x 68 mm, width x height x depth (with glands)
Enclosure, weight	High-impact ABS/PC, IP43 / approx. 0.2 kg

*- approximate value, set as standard without calibration

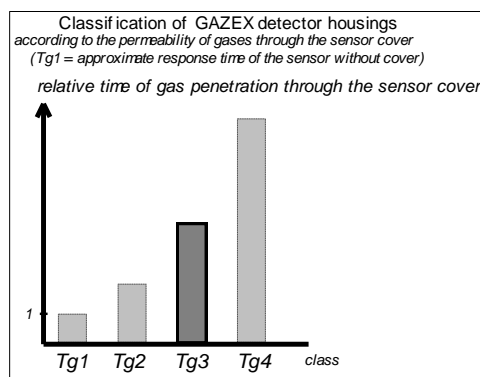

3. CONNECTING DG.EN/M IN THE SYSTEM

Fig.3.1. Block diagram of the bus system with DG.EN/M detectors:

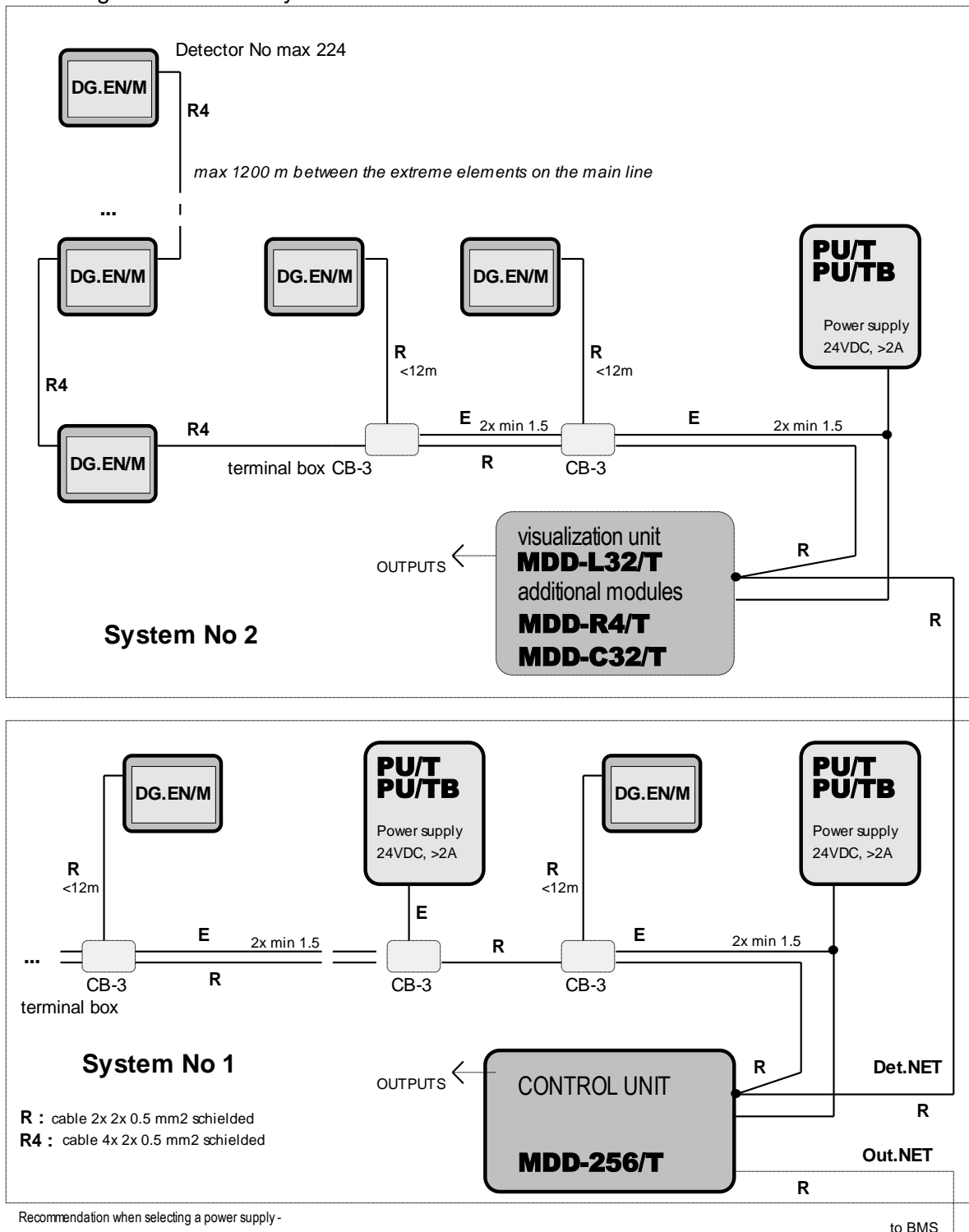

It is recommended to use YTKSY ekw cable – a twisted pair shielded with aluminium foil – for connecting the DG.EN/M detector.

3.1.1. Selection of connection wires for the digital bus.

The bus wires should be selected to meet the following basic criteria:

- copper wires with a minimum cross-section of 0.5 mm², twisted and shielded pairs;
- for a two-wire bus: a separate 24V power cable 'E' (e.g., YDY 2x1.5 or 2x2.5) + communication cable 'R' (e.g., YTKSY ekw 2x2x0.8);
- for a single-wire bus: one cable 'R4' (for longer connections, two power pairs, e.g., YTKSY ekw 4x2x0.8) or 'R3' (for shorter connections, one power pair, e.g., YTKSY ekw 3x2x0.8).

In a real connection scenario, the bus must meet critical conditions:



- 1) The minimum supply voltage of the detector must not be lower than 10V – assuming the system power supply operates at the lowest anticipated voltage level of the power grid (i.e., a voltage drop of at least 10%);
- 2) The length of the wired connections between the most distant devices connected to the bus must not exceed 1,200 m.

TABLE 3.2. Suggested colours for YTKSY ekw 4x2x0.8 wires

CONNECTOR NUMBER / DESCRIPTION	COLOR OF WIRING	FUNCTION
01 / M	blue	Power ground
02 / M	brown	Power ground
03 / M	x	x
04 / +	white and blue	+ power
05 / +	white and brown	+ power
06 / +	x	x
07 / GND	green	RS485 - GND
08 / B-	orange	RS485 - signal B-
09 / A+	white and orange	RS485 - signal A+

All terminals of the DG.EN/M are detachable from the base plate in groups of 3 (blocks), all with double inputs, galvanically connected vertically, allowing the connection of a wire to the next detector. The connector sets 01, 02, 03 and 04, 05, 06 are galvanically connected on the detector's base plate to allow parallel connection of the power-control wire cores and ensure a lower voltage drop on this wire.

The DG.EN/M detector is equipped with special, dual-entry, removable terminal blocks (detachable from the pins on the PCB) that facilitate the connection of the detector and also allow the detector's plate to be disconnected without interrupting the power-communication bus. When connecting, it is essential to adhere strictly to the bus wire colour coding shown in the figure above. This will ensure correct connection to the communication-power bus.



4. INSTALLATION CONDITIONS



The user of the detector and the INSTALLATION TECHNICIAN must be aware of the special design and unusual use of the DG.EN/M detector. This necessitates carrying out all installation and maintenance work with the **UTMOST CARE!**



4.1. The PLACE OF INSTALLATION of the detector on premises at risk of gas emissions has a **FUNDAMENTAL** effect on the correct operation of the device, from the premises security perspective. For this reason, the installation site should be determined by a competent specialist.

In many cases, it can be assumed that the best place to install the detector is (general requirements):

- - as close as possible to the potential source of gas emissions, no more than about **8 m** away (horizontally),
- - in an area unexposed to sunlight, away from sources of strong electromagnetic fields (including mobile phones),
- - away from supply vents, windows, doors,
- - in a place not exposed to the direct influence of: outside air, water vapour, water or other liquids, cooking fumes, exhaust gases from furnaces, dust, mechanical impact, vibration, violent gusts of air,
- - in a properly ventilated place – in the exhaust air stream;
- in a place where the detector can be **ACCESSED** and there is free space of at least 15 cm below the sensor cover (for future servicing).

And in addition (special conditions):

4.1.1. For DG-11(14,73).EN/M calibrated for methane (natural gas, LNG, hydrogen) (lighter than air – accumulates in the upper areas of rooms):

- - on the wall, at a height **NO LOWER than 30 cm** below the ceiling or on the ceiling;
- - **ALWAYS** above the top edge of doors or windows!
- - in a location **NOT** separated from the potential gas emission source by a barrier taller than 30 cm (such as a beam or ceiling tiles).

4.1.2. For DG-22.EN/M calibrated for carbon monoxide (CO) (slightly lighter than air, easily mixes throughout the space):

- - on the wall or pillar, at a height of **approx. 180 to 200 cm** from the floor (but at least 30 cm below the ceiling).

4.1.3. For DG-15.EN/M, DG-61.EN/M calibrated for propane-butane (LPG), HFC (freons) (significantly heavier than air, accumulate in the lower areas of rooms):

- - on the wall or bracket, at a height **NO HIGHER than 30 cm** above the floor level;
- - **NOT** above any depressions in the floor;
- - In a location **NOT** separated from the potential gas emission source by steps, thresholds, or floor channels.

4.1.4. For DG-8R8.EN/M designed for detecting carbon dioxide (CO₂) (heavier than air, at high concentrations – accumulates in the lower areas of rooms):

- - on the wall or bracket, at a height of **approximately 50 cm** above the floor level (for models designed to detect low concentrations of CO₂, i.e., A2 < 5 000 ppm, the height may be up to **180 cm**);
- - **NOT** in the path of external airflow or within the ventilation supply stream;
- - out of the range of air exhaled by people (to avoid false alarms);
- in a location **NOT** separated from the potential gas emission source by steps, thresholds, or channels.

The above-mentioned distances from the emission sources refer to an unimpeded diffusion zone, i.e. a temperature-homogeneous space without mechanical barriers restricting the flow of gases or vapours, without forced air circulation, and without gravitational ventilation. All the factors mentioned above should be taken into account when deploying the detectors.



ATTENTION – IMPORTANT INFORMATION: If there are any changes that significantly affect the correct

operation of the detector, such as a change in the type of hazardous/detected medium, reconfiguration of potential gas emission sources, reconstruction or change of purpose of the monitored room/area, or a change in its use, modifications to the electrical installation or ventilation/heating systems, or changes in the configuration of electromagnetic interference, it is imperative to **verify the selection of detectors, their placement, and wired connections!!!**

4.2. INSTALLATION POSITION: RECOMMENDED – VERTICAL, with the inlet to the measuring chamber facing downwards!

Horizontal installation is permissible – with the inlet to the chamber facing sideways, provided that the detector is not exposed to moisture or other factors and the monitored room has a low level of dust – in this position, thermal compensation may not function correctly.



INSTALLATION POSITIONS:

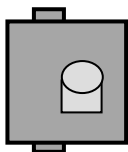

RECOMMENDED – vertical
(possible deviation from the vertical axis $\pm 45^\circ$ requirement!)

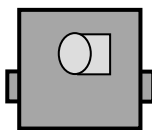

NOT RECOMMENDED (but permissible) – horizontal
(does not meet the splashing resistance

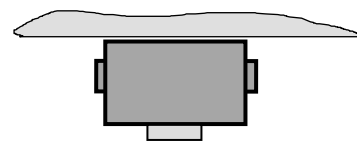

on the ceiling [DG-11(14,73).EN/M only])

NOT PERMITTED:

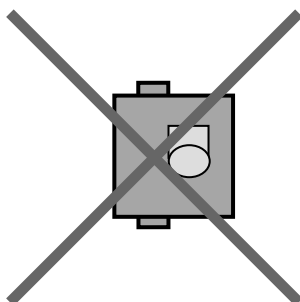

5. DG.EN/M INSTALLATION



Note: The detector is delivered without a pre-assigned address, which is necessary for operation in the Digital Gas Detection System. If the detector is to be installed in a hard-to-reach location, it is recommended to assign a network address in advance (according to section 5.3.2)!

5.1. Attach the detector in the designated location, outside the explosion hazard zone, and free from strong electromagnetic interference. Installation procedure:

- 5.1.1. Unscrew the cover to reveal the mounting holes;
- 5.1.2. Mark the positions of the mounting holes;
- 5.1.3. Secure the detector to the surface using expansion plugs or screws. The detector must be firmly and securely mounted without any looseness.

5.2. Insert the power and communication bus cable through the membrane gland. The membrane gland requires a preliminary piercing of the inner membrane – this should be done carefully, centrally, using a thin crosshead screwdriver (NOT a flathead screwdriver, NOT a utility knife!). Lightly moisten the cable sheath before inserting it into the gland.

In rooms where moisture condensation on the connecting cables may occur periodically, an excess length of the cable should be provided to form a loop just before entering the upper gland.

- 5.2.1. The detector is supplied with pre-installed terminal blocks on all inputs. The terminal blocks can be removed from the connection pins to facilitate wiring.

5.2.2. Insert the stripped ends (6 to 7 mm) of the wire cores into the corresponding terminals of the block (MAINTAINING THE WIRE COLOUR CODING) and plug the terminal blocks into the appropriate position on the detector board.



Note: Incorrect wire polarity may prevent the entire network of detectors from starting up.

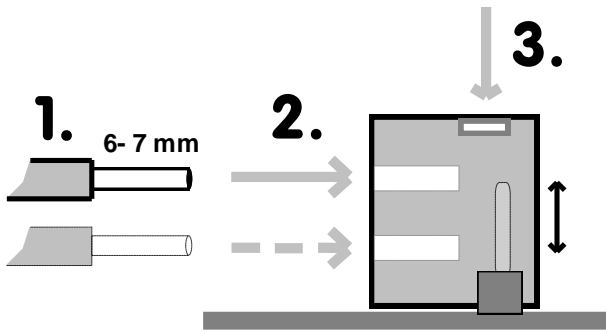

terminal block (as indicated by arrow 3) using a flathead screwdriver.

5.2.2.A. Inserting a conductor into a **self-clamping (double)** type terminal:

1. Remove conductor insulation over a section of 6 to 7 mm (precisely!).
2. Use pliers to push (insert) the stripped conductor end into the round opening of the terminal up to the stop.

A properly inserted conductor cannot be dislodged from the terminal. To release and remove the conductor, press the orange indentation on the upper surface of the



5.2.3. ONLY in devices (DG.EN/M detectors, control module e.g., MDD-256/T) that are located at the farthest ends (with the longest wired connections) should terminators (load resistors) be connected. The DG.EN/M detector does not have a built-in terminator. The terminator can be connected by placing the ends of the terminating resistor into the A+ and B- terminals.

WARNING! – Only two devices at the extreme ends of the bus should have a terminator installed – it is not allowed to install/enable the terminator in any other elements! Failure to comply with this condition may result in the inability to start part or all of the detector network!

5.3. System startup.

5.3.1. Connect the power supply to the DG.EN/M detector network. Upon powering up, a lamp test is conducted, after which the device begins normal operation (the status of the device is indicated by the lamps as shown in Table 1.1).

5.3.2. DG.EN/M addressing procedure (dependent on the cooperating/control devices):

- a) If the DG.EN/M detector network is working with the MDD-256/T supervisory module:
- Ensure that the electrical connections between the detector network and the supervisory module are correct;
 - Ensure that all elements of the detection system are properly powered;
 - Start the detector network addressing procedure in the MDD-256/T module – from the Menu, select: [d.nEt] -> [d.Add] -> select the starting address: 001 and confirm;
 - The detector will signal entry into addressing mode by rapid (approx. 5 Hz) blinking of the 'NET' LED; Confirm the addressing in the detector by briefly pressing the 'S1' button – the detector will store its address (if addressing began from address number 001, the detector will assign itself address 001);
 - Confirmation of the address being stored and exiting the addressing mode is indicated by the 'NET' light turning off;
 - The MDD-256/T module will automatically increment the address (002);
 - Confirm the addressing in the next (and then all other) detectors in the network;
 - The addresses of subsequent detectors will match the order in which addressing was confirmed in the detectors;
 - After confirming the addressing of all DG.EN/M detectors – exit the addressing mode in the MDD-256/T module, and exit the Menu;

Proper operation of the DG.EN/M in the system is indicated by a constantly lit 'POWER' light and occasional single flashes of the 'NET' light (every few to several seconds – as queried by the MDD-256/T).

- b) Addressing can be performed using the DETnet View software by following the steps below:
- Connect the DG.EN/M detector to the computer via an RS-485/USB converter and the installed DETnet View communication software;
 - Switch on the detector;
 - From the software Menu, select '*Connection/Connect*' and in the newly opened window, select the appropriate port number and confirm with the 'OK' button;
 - Go to the '*Tools/Addressing/Address*' menu, and the detector should signal entry into addressing mode by rapid (approx. 5 Hz) blinking of the 'NET' LED;
 - In the newly opened window, select the address to be assigned to the device and press the 'Send' button;
 - Confirm the addressing in the detector by briefly pressing the 'S1' button – the detector will store its address;
 - Confirmation of the address being stored and exiting the addressing mode is indicated by the 'NET' light turning off.
- c) If the detector network is controlled by a different controller (other than MD-256/T), follow the procedure described in the controller's User Manual. The addressing procedure in such devices should include the following steps:
- Connect the DG.EN/M detector to the computer via an RS-485/USB converter and the installed MODBUS-RTU communication software;
 - Switch on the detector;
 - Send the **start addressing** command to the detector: F 06 parameter 0x0101, 0x00, CRC, CRC
Command format: 00,06,01,01,00,CRC,CRC.
 - The detector will signal addressing mode by rapid blinking of the 'NET' light (approx. 5 Hz);
 - Send the **address assignment** command to the detector: F 06 parameter 0x0101, 00, address, CRC, CRC
Command format: 00,06,01,01,00,address,CRC,CRC;
- Confirm the addressing in the detector by briefly pressing the 'S1' button;
The detector will finish signalling the addressing mode and store the ADDRESS as sent in the function parameter initiating the addressing.
- 5.3.3. Checking the detector's network address:
- At any point during the operation of the DG.EN/M, briefly pressing the '**S1** button will display the DG.EN/M detector's network slave address by flashing the green [NET] light as follows:
 - 2 seconds – off;
 - hundreds digit – a proportionate number of rapid flashes (if 0 is one long flash);
 - 2 seconds – off;
 - tens digit – a proportionate number of rapid flashes (if 0 is one long flash);
 - 2 seconds – off;
 - units digit – a proportionate number of rapid flashes (if 0 is one long flash);
 - 2 seconds – off.
- 5.3.4. After confirming the addressing of all DG.EN/M detectors, exit the addressing mode in the controller. Proper operation of the DG.EN/M in the system is indicated by a constantly lit 'POWER' light and occasional single flashes of the 'NET' light (every few to several seconds – as queried by the controller).
- 5.3.5. A simplified procedure for checking the alarm statuses of the DG.EN/M and the outputs of the gas detection system controller can be carried out by triggering an output test as described in section 1 (Table 1.2). The consecutive states of the detector facilitate the verification of the correct connection of the detection system controller's outputs.
- 5.3.6. Install the detector cover (with the gas sensor inlet facing downward).

5.4. The final step in verifying the operation of the **DG.EN/M** is the physico-chemical generation of ALARM statuses in the sensor.

Ensure that the detector is properly powered, correctly signals communication with the controller, and that the warm-up cycle has completed (with the green 'POWER' light continuously on).

5.4.1. SIMPLIFIED TEST (*recommended*):

I. Output and optical signal test – according to the test procedure above – section 5.3.4.

II. Test of the sensor's physical response to gas:

5.4.2. TEST of the sensor's physical response to test gas:

Through the appropriate test cap (TC2-WG), apply the test gas at a flow rate of approximately 0.5 l/min (or under other conditions as specified in the detector's SSW calibration certificate), containing:

- for DG-22... – carbon monoxide concentrations greater than >50 ppm (but <1,000 ppm), for at least 30 sec. (but no more than 1 minute);

- for DG-15... – a propane-butane mixture of > 20% LEL i.e. >0.3% by volume, for at least 30 sec. (but no more than 1 minute);

- for DG-11(-14)... – methane of >20% LEL i.e. >0.88% by volume, for at least 30 sec. (but no more than 1 minute);

- for DG-73... – hydrogen of >20% LEL i.e. >0.8% by volume, for at least 30 sec. (but no more than 1 minute);

- for DG-8R8... – CO₂ of >2000 ppm, for at least 30 sec. (but no more than 1 minute).

illumination/flash of the ALARM (red) light indicates a correct detector response. The illumination/pulsation of the ALARM light (according to Table 1.1 in A1/A2/A3 mode) depends on the concentration of the test gas and the duration of gas exposure to the sensor.

5.4.2.A DG-22.EN/M detector test:

During the first 15 minutes after powering on the detector, the measurement system is in a temporary CO concentration measurement mode – it does **not calculate** the 15-minute weighted average! **During this period, a gas test should be conducted**, and alarm statuses should be generated in the detector by applying test gas. Depending on the concentration of the test gas, the ALARM light should illuminate/flash in a manner corresponding to the appropriate alarm level A1/A2/A3 (according to Table 1.1). After 15 minutes from power-on, the DG-22.EN/M automatically switches to the proper mode, i.e., calculating the 15-minute weighted CO concentration average.

This CO detector operation mode allows for quick, simple verification of a large number of detectors on the bus.

5.5.1. Note: The control module reads changes in the state of the DG.EN/M detector with a delay related to the sequential polling of the entire network of detectors and devices connected to the power/control bus – this delay can range from a few to several seconds.

5.5.2. If the alarm signal from the DG.EN/M detector persists longer than the delay time programmed in the control module, the appropriate alarm output of the module will be activated.

Record the date and any comments regarding the startup in the Periodic Inspection Record – the template is available at www.gazex.pl.

After a positive result from this test,
the DG.EN/M Detector
can be considered operational and functional.

5.6. Ensure that the detector cover is properly screwed on and sealed.

It is recommended to seal the detector cover (especially if the DG.EN/M is accessible to unauthorised persons).

6. MAINTENANCE / OPERATION

DG.EN/M detectors are maintenance-free electronic devices, there are no control elements inside the devices. They are built using semiconductor components with a long service life.

Therefore, the only maintenance required is a periodic inspection of the system:

A) – periodic inspection of the permeability of the sensor cover on the faceplate by vacuuming;

B) – periodic check of the operation of the system in accordance with procedure 5.4. in the 'Installation' Chapter.

The recommended frequency of periodic inspection is not less than every 3 months.

C) – the periodic check should also be conducted EVERY TIME after specific operating conditions of the detector have occurred, i.e:

- 1) the occurrence of extreme conditions, e.g. high gas concentration, high or very low temperature (outside the recommended operating range), high periodic dustiness,
- 2) the occurrence of high concentrations of gases or vapours of liquids whose presence in the controlled area was not anticipated,
- 3) long-term (>8h) operation with the alarm status activated,
- 4) after a power outage of more than 3 days,
- 5) after renovation or installation work that may affect the operation of the detector/system or its configuration; etc.

After specific operating conditions of the DG.EN/M have occurred as described in points 1 to 3, it may be necessary to calibrate the detector (correct the setting of its alarm levels).



The above-mentioned frequency of System inspections can be considered to be in line with good engineering practice, based on over 30 years of experience of the Manufacturer. However, it should be emphasised that in the specific conditions of a given Customer, this frequency may be subject to modification, based on the principle that the more important (from the Customer's/User's point of view) the system is, i.e. the more the Customer cares about efficient, failure-free operation of the facility of which the system is a part, the more frequently the system should be inspected. When expecting to increase the level of operational safety of their facility, the Customer should inspect the detection system more frequently, e.g. every 4 weeks or prior to each important event/measurement. On the other hand, where the role of the detection system is considered to be less important or based on the Customer's own assessment of the reliability of the facility's components, the Customer/User may decide to extend the inspection period e.g. to 6 months.



THE INSPECTION INTERVAL MUST NOT EXCEED 12 MONTHS!

NOTE: ALL results of the periodic inspection, any malfunctions noticed in the detector, power interruptions and the fact of operation under extreme conditions must be recorded in the **Periodic Inspection Record** (template *downloadable from www.gazex.pl*) on pain of losing warranty rights;

D) – as the semiconductor gas sensor may have a natural tendency for increased sensitivity over time, an excessive lowering of the alarm thresholds may occur after a period of approximately 3 years of operation (see Technical Parameters – Long-term stability). This does not change the operation of the detector, but in such situation, it is nevertheless **recommended** (especially if the User notices frequent reactions of the system to relatively low gas concentrations) to calibrate the device, i.e. adjust the setting of the alarm levels,

at least every 3 years of detector operation.



The expiry of this recommended period of time is signalled in the detector only visually (while maintaining full functionality at the outputs): the **POWER** indicator flashes rapidly (several times per second).

Calibration can be carried out by the Manufacturer or an Authorised Service Centre on site or after the sensor module has been delivered to the above-mentioned entities.

Dismantling of the sensor module by the User and sending it back to the Manufacturer for calibration seems to be the fastest and the most economically justified way of maintaining full functionality of the device.

E) – in the event of renovation work, painting, floor impregnation, etc., it is essential to switch off the power supply to all detectors for the duration of the work and for the time required for the paint coating to dry completely and for the premises to be ventilated. It is also necessary to gas-proof the detector with a polythene bag (and remove the bag before switching the power back on).



E. SENSOR REPLACEMENT

WARNING!

The sensor removal procedure must be carried out with the utmost care to avoid damaging the gas sensor.

Removal of the sensor module:

- Disconnect the power supply to the detector (bus);
- Remove the enclosure cover;
- Disconnect all bus terminals (detach from the pins);
- Gently grasp the edges of the rectangular sensor board with your fingers;
- Gently pull it out of the socket;
- Install the cover (if there is no replacement sensor module available);
- Transport/store the module in a tightly sealed plastic bag, in shock-proof packaging (wrapped in soft foam, sponge).

It is permissible to connect the power supply to a detector without the sensor module – the detector will signal the absence of the sensor by 2 short flashes of the yellow fault light [FAULT].

Mounting the sensor module:

- Make sure that the power supply is disconnected;
- Remove the enclosure cover;
- Grasp the edges of the rectangular sensor module board with your fingers so that the connector pins are vertical and the positioning hole is in the lower left corner;
- Gently insert the module along the inner right wall of the detector enclosure (so that the positioning hole of the sensor module is on the positioning pin);
- Press lightly until tangible resistance;
- Install the enclosure cover so that the foam gasket of the grey sensor cover is precisely aligned with the ventilation hole of the cover.

Once the power is switched on, the green indicator [POWER] should flash for about 30 sec. and then be on continuously.

7. WARRANTY TERMS AND CONDITIONS

The detector is covered by the Standard Gazex 3-year warranty plus (SGG3Y+) for a period of 36 **MONTHS** – as of the end of the year in which the device was manufactured, according to the terms and conditions of that warranty posted on www.gazex.pl.

The manufacturer does NOT print or issue warranty cards = the basis for determining the warranty period is the year of Manufacture shown on the device's nameplate.

Selected extracts from the SGG3Y+ terms and conditions:

- ...
1. GAZEX guarantees the efficient operation of devices of its own manufacture for the period up to the end of the year in which the device was manufactured and for another three years.
 - 1.1. The year of manufacture is determined on the basis of the device's nameplate (*warranty cards are not issued!*).
 - 1.2. If the nameplate is illegible – the year of manufacture will be determined on the basis of the serial number or the code labels on the components (*if any*) together with the records in the GAZEX electronic manufacturing surveillance system. Such verification is subject to a charge. The fee is PLN 50.00 net for each started verification of a batch of up to 10 devices.
 - 1.3. Non-identifiable devices, i.e. with a damaged/illegible nameplate or no nameplate at all and with the GAZEX logo removed/covered permanently, shall not be subject to the warranty.
 - 1.4. The SGG3Y+ warranty covers all devices manufactured by GAZEX after 1 January 2021 which display the year of manufacture '2021' or later on the nameplate.

- ...
4. The warranty does not cover damage caused by:
 - a) mechanical shock, vibration and effects, thermal effects and chemical effects;
 - b) damages resulting from improper storage, faulty installation or improper operating conditions contrary to the device's User Manual;
 - c) failure to carry out periodic maintenance or by other negligence;
 - d) deliberate action by the user, third parties or persons not authorised to carry out repairs;
 - e) lightning, power line surges, or electrostatic charges;
 - f) force majeure or other events beyond the Manufacturer's control.

Consumables including, but not limited to, fuses, batteries, built-in batteries, gas sensors (which are covered by the GAZEX OGG+ Limited Warranty), porous sintered components are not covered by the warranty.

- ...
6. The warranty rights cease to apply in the following cases:
 - a) damage to the factory seals, service seals or identification marks on the device/components;
 - b) interference with the device's internal systems or making any other changes to the device or control software or when the device is operated with non-original components not supplied by GAZEX;
 - c) failure to carry out periodic maintenance activities, confirmed by systematic entries in the Periodic Inspection Record (enclosed with the device or devices cooperating with it) and indicated as necessary in the device's User Manual.

...

The full terms and conditions of SGG3Y+ are available at www.gazex.pl.

The aforementioned warranty terms and conditions apply to devices operated in Poland.

FAILURE TO COMPLY with all the terms and conditions of installation and operation of the detector as described in this manual (which shall include keeping the Periodic Inspection Record) will result in the loss of warranty rights.

An extended version of the Periodic Inspection Record is available in .pdf format at: www.gazex.pl.

NOTE:

Any complaints require that a warranty repair request or post-warranty repair request is registered on: <https://www.gazex.com/pl/serwis>

There is a possibility to extend the warranty to 5 years - Gazex Extended Warranty 5 year plus (RGG5Y+), according to the terms and conditions of RGG5Y+ available at www.gazex.pl.